

STARTERS GUIDE – PART I

A GUIDE TO INTRODUCE NEW USERS TO AND HELP
REPLICATE THE BEDINI RADIANT CHARGING PHENOMENON

*Bedini Peswiki Index Document
Modified and Edited by Miki on September 28, 2007*

TABLE OF CONTENTS

TABLE OF CONTENTS	2
INTRODUCTION	3
SCHEMATICS	3
SCHEMATIC BY BEDINI.....	3
SCHEMATIC BY SHELDON.....	4
MATERIAL LIST	4
ALLIGATOR CLIPS	4
BATTERIES, RECHARGEABLE.....	5
BICYCLE WHEEL RIM -- OR OTHER ROTOR DEVICE	5
COIL SPOOL.....	6
DIODE	6
DIODE, 1000 VOLT	7
HEAT SINK.....	7
MAGNET CORE (WELDING ROD).....	8
MAGNET WIRE FOR PRIMARY COIL WINDING.....	8
MAGNET WIRE FOR TRIGGER COIL WINDING.....	9
MAGNETS.....	9
NEON LAMPS	9
RESISTOR.....	10
SUPER GLUE.....	10
TAPE.....	11
TRANSISTOR	11
WOOD (STAND).....	11
TOOLS NEEDED	12
CONTACTS	12
DIGIKEY	12
RADIO SHACK.....	12
ASSEMBLY	13
BUILDING THE FRAME	13
FASTENING MAGNETS TO WHEEL	13
WINDING THE COILS.....	13
FILLING CORE.....	14
UPDATED COIL WINDING INSTRUCTIONS BY LEE.....	14
SOLDERING THE CIRCUIT.....	14
CAUTIONS	15
OPERATING PROCEDURES	15
TURNING THE MOTOR ON	15
TUNING THE MOTOR.....	15
PERFORMANCE EVALUATION.....	15
TIPS ON BATTERY CONNECTIONS, TUNING, AND BEARINGS	15
<i>Connecting the Batteries</i>	16
<i>Adjusting Resistance</i>	16
<i>One 1N4007 to Each Battery in Bank</i>	17
<i>Reducing Bearing Friction Tip by Oneness</i>	18
CONCLUSION	18
REFERENCES	18

INTRODUCTION

This document is to help group members replicate the Bedini Pulse Charging Systems. The replications begin with the Simplified School Girl (SSG) energizer. It is part of the group introduction to the study of Radiant Charging Systems or the exploitation of an unproven source of energy called vacuum energy. It is by no mean an exhaustive source. Nothing in this document is written in stone. Users are encouraged to innovate, study, and ask questions as they see fit. Nothing is guaranteed as to the outcome of a replication. Users are left to draw their own conclusion through experiments and further research. It is particularly important that the study results are shared with the rest of the group.

Key words: Energizer, Rotor, Stator, Coil, Transistor, Diode, Tuning, Charge Capacity, Discharge Capacity

Disclaimer!!! Use caution. All risks and damages, incidental or otherwise, arising from the use or misuse of the information contained herein are entirely the responsibility of the user.

SCHEMATICS

SCHEMATIC BY BEDINI

Bedini School Girl (Simplified) Schematic Sketched by John Bedini for this project at PESWiki.com. Sept. 27,

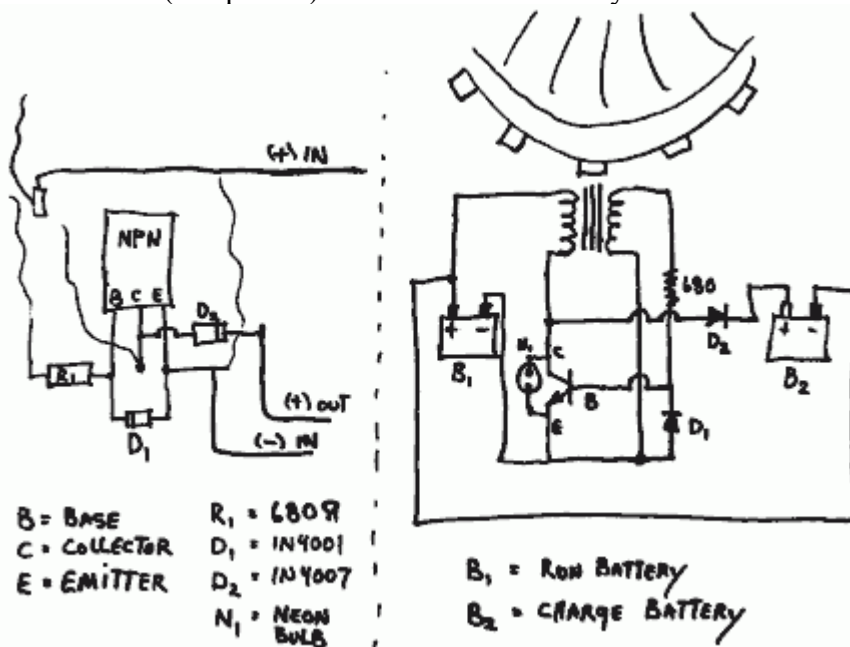

2004.

Schematic on left corresponds to the photo [below](#).

KEY:

- B = Base
- C = Collector
- E = Emitter
- R₁ = 680 Ohms resistor
- D₁ = 1N4001 Diode
- D₂ = 1N4007 Diode
- N₁ = Neon Bulb
- B₁ = Run Battery
- B₂ = Charge Battery

SCHEMATIC BY SHELDON

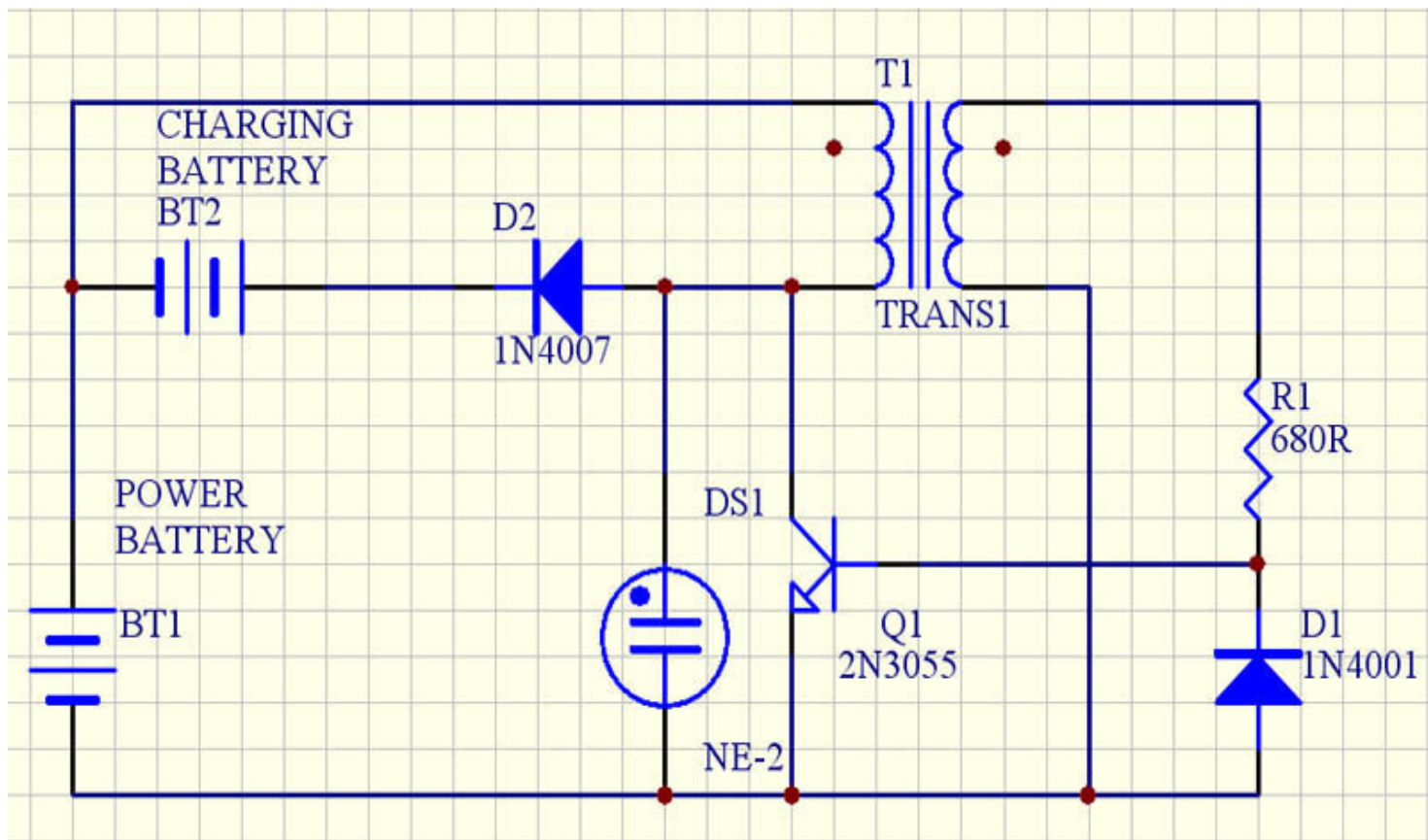

MATERIAL LIST

The following is the list of materials required to replicate the Bedini School Girl energizer. Parts are listed alphabetically. It is important to buy extra replacement components in the event of failures.

ALLIGATOR CLIPS



Purpose

To connect batteries to circuit

Specifications

Wires need to be larger than 20 AWG. Connectors need to be rated for at least 5 Amps.

Tolerance

Wide range, with the above minimums in mind, especially the wire and clip ratings.

Quantity

At least two per battery

Sourcing

Google for “alligator clips” providers

Estimated price

Less than \$7.00 for set of five

BATTERIES, RECHARGEABLE

Purpose

Providing input energy, and receiving output energy from the system. Note that the same battery can't be used simultaneously as both input and output in this configuration; closed loop will not work.

Specifications

6 to 24 volt batteries / 12-volt lead acid batteries recommended.

Quantity

At least two: one for input, one for output. More recommended for experimental options (1) **Control**. An identical battery to the input battery should be obtained for a control -- to test the discharge parameters of a battery independent of the circuit under the same discharge parameters being put to the input battery for characterization. (2) Additional batteries of the same voltage and impedance can be added to the output in parallel (e.g. to graphically demonstrate more output than input). This is the widest and most crucial variable in the system. Plan ahead the experiment you want to run before purchasing.

Tolerance

The voltage of the batteries is not crucial, and can be somewhere in the range of 6 to 24 volts for the SSG energizer. However, *the input and output batteries need to be matched in their voltage and impedance* (size). There can be more than one battery on the receiving end, connected in parallel, of a matched voltage and impedance (size) of the input battery. For your first replication of this, you will want to use new batteries so that bad batteries will not be possible reasons for malfunction of the circuit. Not all rechargeables are suitable for receiving charge from this set-up. Lead acid recommended.

Sourcing

Google the word "battery" for the best source possible

Estimated Cost

\$5 (or even free if you rummage) to \$75 USD each, depending on make/source/size.

Battery Care

It will be important for you to know your batteries' optimal operating parameters from their manufacturer or other competent rating service **so that you do not damage them by charging or discharging too fast or too high/low**. As long as you are using the Bedini School Girl circuit to **charge your batteries**, you will not need to worry about speed or level of charging. But if you use another apparatus to charge your battery, you will need to know your batteries' charging parameters. If your input and output batteries are matched in voltage rating and impedance (size) the circuit inherently balances the charging rate to a level that is not only safe but even beneficial to the receiving battery. Overcharge is not nearly the concern with the Bedini School Girl circuit as it is with other chargers. Batteries actually perform better under frequent use with the Bedini School Girl circuit, than if you let a few days pass between uses.

Performance

Obtain the battery data sheets from the manufacturer or on the internet. The following curves are of importance: Voltage, Current, Charge capacity, discharge Capacity profiles.

BICYCLE WHEEL RIM -- OR OTHER ROTOR DEVICE



Property

Non-magnetic

Purpose

To serve as Rotor

Specifications

24-inch diameter would be fine. Bearings should be in good shape. Rotation should be fairly straight. **Make sure the rim is non-magnetic.**

Tolerance

± 10 inches in the diameter (not crucial at all). The rotor doesn't have to be bicycle wheel. Any non-magnetic rotating wheel of similar size and weight should work. These plans are for a 24-inch rim. If you go smaller or larger than 24 inches, you will need to adjust the number of magnets accordingly so that the spacing is approximately the same. Also, if a rotating axis is desired to convey the torque of the wheel, an alternative bearing configuration is required.

Source & Price

Free (should be able to rummage one from junk, yard sale, thrift store, bike repair shop, etc.) Take a magnet of some kind with you to make sure the rim is non-magnetic.

Variants

Other rotor devices used successfully: - CD ROM drive mechanism, - target board; - Child's bike wheel (plastic). Use your imagination.

Bearings

Bearings for bicycle wheels are terrible, even new ones. Recommend www.VXB.com, remove grease (use a citrus degreaser), and add lubricant (or 5W20 fully synthetic motor oil).

COIL SPOOL



Purpose

Form for supporting the coil windings.

Specifications

Plastic, 3 inches inner diameter by 3 inches long, with 3/4 inch center opening

Quantity

One

Tolerance

Opening needs to be $\pm 20\%$. Length of spool can be $\pm 40\%$. Material needs to be non-metallic, non-magnetic, and adequately sturdy.

Sourcing

Google for "Coil Spool" providers

5lb Pittsfield Spool: <http://www.precision-spools.com/plastic-spools.html>

DIODE

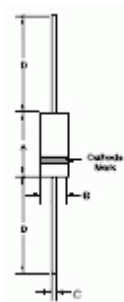

Purpose

Protect the transistor base-emitter junction.

Specifications

Recommended: 1N4001; 1 A, 50 V
(Some models have used the 1N914)

Parameters

50-300 volt range; low power, fast silicon diode

Sourcing

Google for "Diode" providers

Estimated cost

Less than \$0.50 each

DIODE, 1000 VOLT

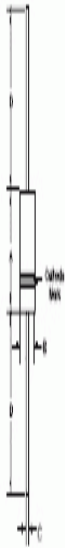

Purpose

Assure one-way flow of energy from circuit to receiving battery.

Specifications

1N4007 (1000 Volt; 1 Amp) [A sister component to resistor 1N4001]

Tolerances

High volt rating very important; a lower Amp rating may work.

Quantity

One

Sourcing

Google for "Diode" providers

Estimated cost

Less than \$0.50 each

HEAT SINK



Sample scrap of aluminum that could be used as a heat sink

Purpose

Dissipate heat from transistor. (Ratings of transistor should be adequate for circuit, and no heating result. This is a precautionary measure.)

Specifications

4" x 4" x 1/16" aluminum plate

Quantity

One

Tolerance

Size not crucial; probably shouldn't be too much smaller than the above dimensions.

Sourcing

Local recycler or junk yard

NAPA part number BK 735-4369 is a fuel pump block-off plate made of aluminum, and is about of the dimensions above, and should work just fine. Approx. \$4.99

Estimated Price
Free, or nominal

MAGNET CORE (WELDING ROD)



Purpose

To provide a low reluctance path that increases the magnetic flux through the coil.

Specifications

Low reluctance, high permeability magnetic material: Welding rod; 0.042" inch diameter copper coated steel rod, 3 feet long. (Will be cut to length of the coil spool)

Quantity

Get 3-5 lbs. (around 10 rods of 3 feet each).

Tolerances

Rough cut okay. Diameter is not crucial. It could be smaller by 50% or larger by 100%.

Sourcing

Available at your local welding supply store (such as Oxyarc) or hardware store (such as True Value or Ace) Try also an auto parts store. Look up industrial supplier or welding supplier in yellow pages of phone book. Phone them; ask for open box item at school project prices.

Estimated Price

\$0.60 per rod

Consideration

The thicker the rod, the harder it is to cut. You're going to be cutting a lot to fill the spool hole.

MAGNET WIRE FOR PRIMARY COIL WINDING



Purpose

The purpose of the 20 AWG is to power the motor and generate high voltage pulses for the secondary battery. It is wound parallel with the 23 AWG magnet wire.

Specifications

The 20 AWG wire should be insulated.

Tolerance

20 AWG or larger gauge wire is recommended.

Quantity

450 to 900 turns correspond to about 175 to 350 feet of wire without discontinuity.

Sourcing

- Google for "magnet wire" providers
- Try [eBay](http://www.eBay.com) (<http://www.eBay.com>)

Resources

[OZ.net explanation of purpose and parameters of magnet wire](http://www.oz.net/~coilgun/theory/magnetwire.htm) (<http://www.oz.net/~coilgun/theory/magnetwire.htm>)

MAGNET WIRE FOR TRIGGER COIL WINDING



Purpose

The 23 AWG magnet wire provides the energy needed for switching the transistor ON and OFF. It is wound parallel with the 20 AWG magnet wire.

Specifications

The 23 AWG is recommended to be copper enamel coated.

Tolerance

The 23 AWG wire can be of the same or smaller gauge than the power winding.

Quantity

450 to 900 turns correspond to about 175 to 350 feet of undiscontinuous wire.

Sourcing

See above.

MAGNETS



Purpose

Affixed to wheel to both (1) transduce motor action to the wheel (2) induce an emf into the coil terminals.

Specifications

Ceramic 5; dimensions: 1" x 2" x 3/8"

Quantity

Start with 16 singles for a 24-inch wheel, later additional magnets can be stacked to the wheel. Get some extra in case of breakage. You also might consider one or two for a control, to measure Gauss before and after experimental runs.

Tolerance

Must be ceramic (strontium ferrite). Number of magnets is not essential, though an even number and even spacing will be necessary if you wish to try and add more coils later.

Source

Google for "Ceramic Magnets" providers

E-bay for anywhere in the world

For Canada --> <http://www.indigo.com/magnets/ferrite-magnets.html>

NEON LAMPS



Purpose

The lamp provides a path for the output energy in case the receiving battery is disconnected while the motor is running. This prevents burn-out of the transistor. The light should not go ON unless the output battery is disconnected.

Specifications

Chicago Miniature Neon Base Wire Terminal T-2 65VAC .6mA NE-2, 90-Volt DC neon bulb

Quantity

One

Make & Model

A1A by Chicago Miniature (definite)

See also Lumex P/N GT-NE3S1025T, [lumex.com](http://www.lumex.com) (<http://www.lumex.com/product.asp?id=1000657>) free sample

Source

[Mouser.com](http://www.mouser.com) part number 606-A1A (<http://tinyurl.com/65apu>) Estimated Factory Lead Time: 1 week.

Estimated Price

\$0.38 USD each

RESISTOR



Purpose

Set or control the device operational mode.

Specifications

680 Ohms should work well for this particular arrangement.

Tolerance

47 ohms to 20k ohms; 1/2 W to 2 W

Quantity

One, for bare minimum, but if you want to be able to tune your device, you should get one 47 ohms resistor and one 10k ohms potentiometer to connect in series.

Sourcing

[digikey.com](http://www.digikey.com) part number 680W-2-

[ND](http://www.digikey.com/scripts/DkSearch/dksus.dll?Detail?Ref=228167&Row=136988&Site=US) (<http://www.digikey.com/scripts/DkSearch/dksus.dll?Detail?Ref=228167&Row=136988&Site=US>) - includes component spec information.

Radio Shack has a wide range of resistors and potentiometers.

Estimated Price

\$0.23 USD each, they usually come packaged in 5 or 10. Potentiometers run around \$3.00.

SUPER GLUE

Purposes

Help secure the inductor core and magnets to the rotor.

Specifications

Standard super glue

Quantity

Will need quite a bit to secure all the welding rods (e.g. **four tubes** of 3 gm)

Tolerance

Any adequate glue will do. Tape can be used in some places.

Sourcing

(Most hardware stores and grocery stores should have it)

[3 gm Super Glue Adhesive](http://www.wesecure.com) (<http://www.wesecure.com/super-glue.htm>) \$0.95 each

TAPE



Purpose

Provide second level adhesion of magnets to wheel (beyond just glue) and insulate bare wire connections.

Specifications

One-sided, preferably electric tape, or duct tape, or nylon reinforced tape.

Tolerance

Any tape that is adequately sticky and non-magnetic

Quantity

Enough for the circumference of your wheel plus a little for overlap and do-over.

Sourcing

Most any store.

[UU77](http://www.uu77.com/tape/electricaltape.asp) (<http://www.uu77.com/tape/electricaltape.asp>) \$1.09 / roll; \$0.20 / 10 rolls.

TRANSISTOR

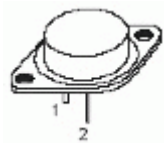

Purpose

Switching

Specifications

2N3055 Transistor, 100V, TO-3 case; fully metal

Tolerance

Get exactly the specified component.

Quantity

One for the circuit and several extra in case of thermal or electrical breakdown

Sourcing

See [Digikey.com](http://www.digikey.com) part number [2N3055OS-](http://www.digikey.com)

[ND](http://www.digikey.com) (<http://www.digikey.com/scripts/DkSearch/dksus.dll?Detail?Ref=232453&Row=71372&Site=US>)

(View [spec sheet](http://rocky.digikey.com/WebLib/ST%20Micro/Web%20Data/2N3055,%20MJ2955.pdf) (<http://rocky.digikey.com/WebLib/ST%20Micro/Web%20Data/2N3055,%20MJ2955.pdf>))

Estimated Cost

\$2.10 USD each

WOOD (STAND)

Purpose

To hold the wheel steady, fasten the circuit, and hold the coil.

Specifications

Plywood or solid wood

Quantity

One sheet approximately 3' x 2' feet square by ~3/4" inch thick (to be cut into three pieces -- two for uprights and one for base)

Two lengths of 2" x 6" or larger of about 6 inches long (to hold coil and stabilize uprights)

Tolerance

Any non-magnetic material of size and thickness adequate to hold the wheel

Sourcing

Available anywhere; try any construction site or do-it-yourself friend's garage; or junk yard. Last resort, try lumber yard or hardware store.

Estimated Price

Free, from scrap pile (any construction site); or \$17.00 for new 4' x 8' sheet of particle board; \$3.00 for new six-foot 2" x 4"

TOOLS NEEDED

- Wire cutter
- Heavy Duty Cutter to cut the welding rods to length (may want to use cutter available where you purchased the rods).
- Carpenter tools to fabricate the stand for the wheel. (e.g. jig saw to cut wood).
- Soldering gun and solder.
- Metal drill to put hole in aluminum heat sink to fasten circuit to device.
- Screw driver and 2-4 screws to screw heat sink to stand.
- Paintbrush and paint or sealant, to apply paint or sealant to wood.
- Skill-Saw to cut boards.
- Drill to wind the coil.

CONTACTS

DIGIKEY

[Digi-Key Corporation](http://www.digikey.com/digihome.html) (<http://www.digikey.com/digihome.html>) 701 Brooks Avenue South Thief River Falls, MN 56701 USA

Phone: 800-344-4539 or 218-681-6674 Fax: 218-681-3380

Email: webmaster@digikey.com

RADIO SHACK

1-800-THE-SHACK (1-800-843-7422)

ASSEMBLY

BUILDING THE FRAME

- Stand needs to have front-back and left-right stability.
- Rotor needs to be made of non-magnetic material.
- Rotor bearings should be low friction and non-magnetic for small diameter rotor.
- Plan for ~1/8 inch gap or less between the coil spool and the wheel with magnets glued and taped.
- Frame material should be non-magnetic, but some metal can be present.
- The smaller the air gap between the magnets and coil the higher is the motor's performance.

FASTENING MAGNETS TO WHEEL

- Use a compass to determine "N" the north end of your magnets. The Earth's North Pole is magnetically south, so the "north" end of your compass will be attracted to the "south" end of your magnet. ([ref \(http://online.cctt.org/physicslab/content/PhyAPB/lessonnotes/magnetism/magnetism.asp\)](http://online.cctt.org/physicslab/content/PhyAPB/lessonnotes/magnetism/magnetism.asp)) North faces out -- toward the coil.
- Label your magnets.
- All magnets face the same direction (north out).
- Magnet spacing does not need to be uniform unless you are going to attempt more than one coil.
- Determine an equal spacing for the magnets about the perimeter of the wheel and mark where they should go. This is not crucial to proper operation with one coil, but if you want to later add more coils (each with a separate circuit), symmetrical spacing will be important for symmetrical firing. If your wheel diameter is more or less than the ~24 inches called in these plans, adjust the number of magnets accordingly to be within the same range of spacing between magnets. You don't want to get your magnets much closer than 1.5 - 2 widths apart.
- If you wish to use more than one coil, each coil will need its own complete circuit. All coils will need to fire in unison, so the magnet spacing will need to be uniform. Spacing between magnets should not be less than 1.5 - 2 magnet widths (whichever way you have them oriented).
- Use super glue and/or tape (or rubber bands, or ...) to affix the magnets.

WINDING THE COILS

"Fill the spool." Approximately 450 to 900 turn

- Wind the two wires on the coil together.
- It is very important that the two wires be next to each other the entire distance of the winding.
- Arrangement of the winding is not crucial. There is no pattern required. Symmetry is not required. Think fishing spool or kite spool, and you'll be fine. The window of tolerance is very wide here.
- You might use a drill to spin the spool. A chordless drill generally can turn slower, making it easier to count turns and to make sure the two wires are wound parallel the whole distance.
- John says the exact number of turns on the coil is not crucial. Close is adequate. The window of tolerance is quite wide here. However, an exact count will be necessary for scientific rigor in documenting and reproducing.
- Keep track of input output pairs.

Tips

Counting visually is nerve-wracking and prone to error. Use an audible trigger in winding (e.g. a clacker on the spool). Alternatively, you might affix tape to both ends of spool, protruding outward around 1/2 inch. This will hit your hand as the spool turns, helping you to count turns.

FILLING CORE

- Be sure to have the side that will be facing the magnets flush with the top of the spool so you can spin your magnets close to the spool without hitting a rod in the core.
- You might drill a 1" inch hole in your base around 1/2" deep for the other side of the core to protrude into, so you don't have to cut your rods short.
- Use glue on each rod to keep it from moving.
- Tap the last few rods in with some light object until you can't fit any more.

UPDATED COIL WINDING INSTRUCTIONS BY LEE

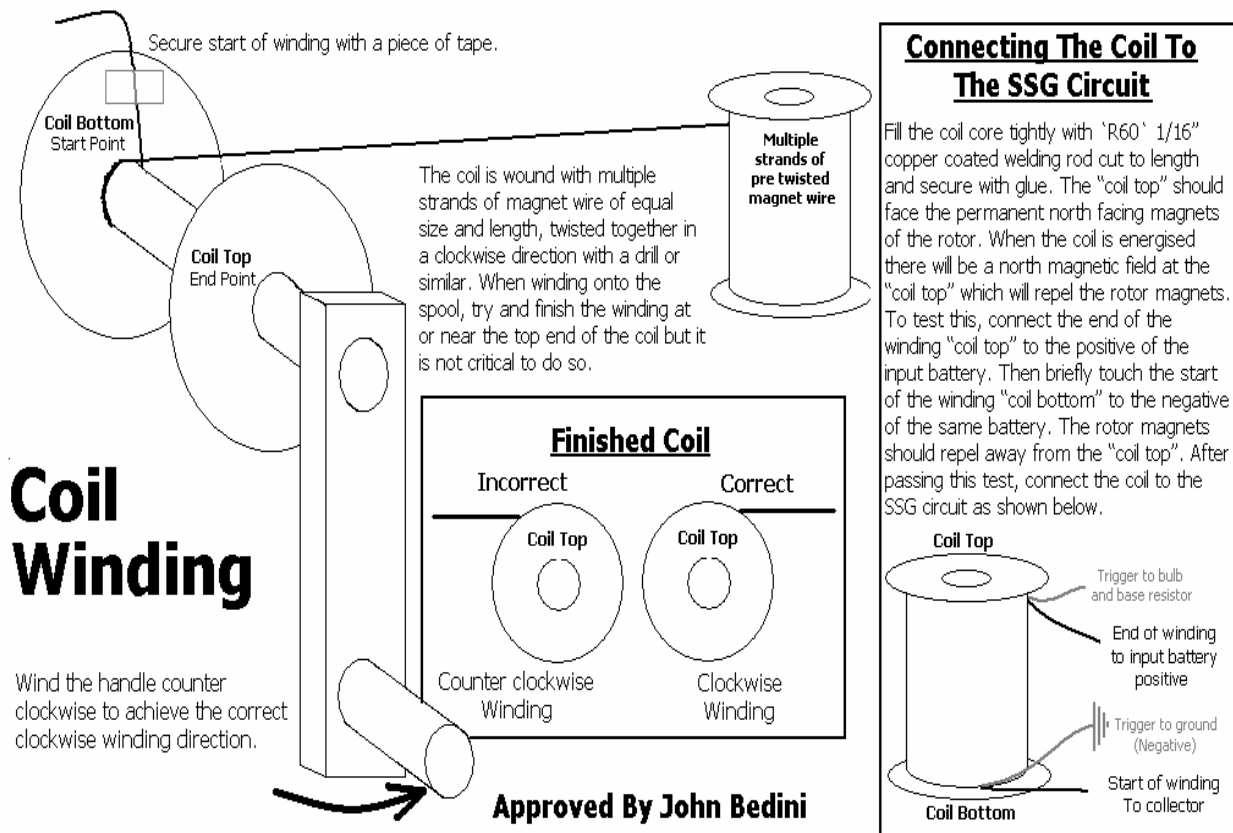

SOLDERING THE CIRCUIT

- Try to keep all wires as short as possible.
- Don't overheat your diodes, resistor, or transistor when soldering.
- If you don't know how to solder, you could use wire nuts or even nuts/bolts to secure your connections.
- Make sure the circuit works before soldering the connections. Alligator clips can be used to hold things in place until you solidify them.
- A little 9-V battery can be used to test the circuit. (Sterling's suggestion)
- John keeps the wires in his circuit as short as possible, going nearly to the quick when fastening his diodes to the transistor. The circuit will work with the wires being longer, but he says it works better when they are short.
- Also, be sure to use a heavy gauge wire when connecting your batteries in parallel or series.

CAUTIONS

- [CAUTIONS](#) - Dangers associated with this project are mainly with the batteries, but also with wheel rotation and soldering. Be sure you understand the risks and that you take necessary precautions.
- While this design can deliver some good shocks, they are not of a dangerous level.
- If the neon bulb is not in place, the transistor is likely to burn out if the device is run without a receptacle for the radiant energy (e.g. a receiving battery). The neon bulb absorbs the excess output energy and serves similar to a shock absorber or fuse (though nothing is "tripped" and has to be reset).

OPERATING PROCEDURES

Objectives

1. Turning the energizer ON
2. Tuning the energizer
3. Charging a battery with the energizer
4. Evaluating the energizer performance for unity only meaning charging an empty battery from a fully charge battery.

TURNING THE MOTOR ON

To run the motor, connect circuit and give the rotor a spin (by hand or some other external mechanical input). It will then accelerate or decelerate to a point of equilibrium. At some resistances in the circuit, there is more than one stable rate of rotation.

TUNING THE MOTOR

Once the energizer is running, adjust the base resistance for minimum input current draw and high peak voltage. It is important that motor operation is sustainable at these values.

PERFORMANCE EVALUATION

Once the energizer is configured for optimum operation, place a fully charge battery on the input and an equal size fully discharge battery on the output. Let the machine run until the input battery reaches the manufacturer specified minimum discharge voltage. Measure the output battery capacity by fully discharging it (to minimum voltage) into a known load. Compare the output battery capacity to that of the input battery.

TIPS ON BATTERY CONNECTIONS, TUNING, AND BEARINGS

Note that all tips are optional. No one is required to follow them to the letter to get full performance out of the device.

- In functional application, you should not draw power from the same battery that is presently being charged. You should have one bank of batteries under charge, and another for discharge, and then switch between them.
- See [Battery Characteristics](#)

Connecting the Batteries

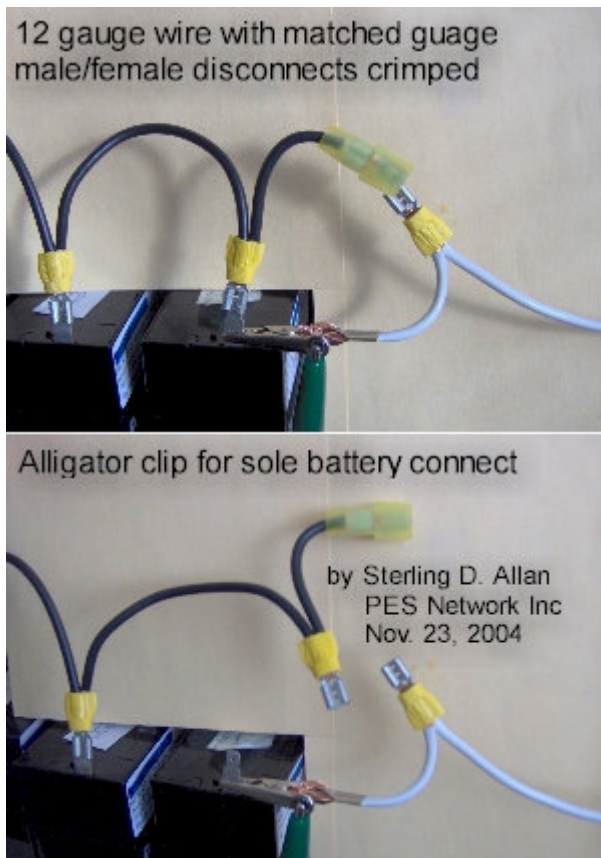

Once your system is confirmed running, you will want to beef up your connections to optimize the effect. Use a heavy gauge wire and terminal connectors with crimping.

The above photo shows a set-up for rotation of batteries from the back end to the front, allowing for single battery charging (fresh from the front) while that battery comes up the same voltage as the bank of batteries, so they can then be connected in parallel.

Adjusting Resistance

Note that the arrangement includes a switch to enable meter readings without extended disconnection of the circuit. Depending on how responsive the meter is, the circuit is interrupted for maybe one or two seconds using this method.

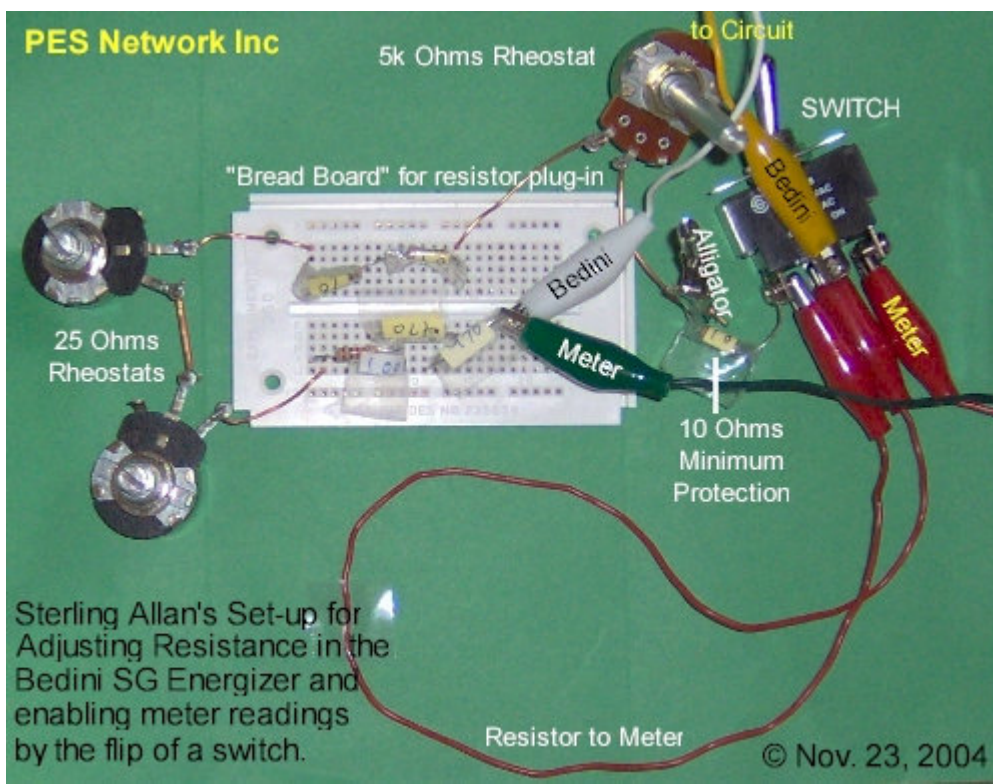

The 25 Ohm resistors give a fine-tuning capability. The bread board enables hard resistor plug-in to the appropriate range desired. The 5k Ohm potentiometer enables a wide berth of tuning.

Note: the 5k ohm potentiometer tends to be unstable in how it holds the resistance. If you wish to lock into a particular resistance, you should consider hard wiring the resistors into the bread board and bypassing the 5K potentiometer.

One 1N4007 to Each Battery in Bank

Dec. 9, 2004 http://groups.yahoo.com/group/Bedini_SG/message/431

Peter and John recommend that we set up our 1 to 4 battery arrangement according to the followings:

Purpose

To isolate each of the batteries in the back-end charging bank

Method

In addition to the 1N4007 diode coming from the circuit to the batteries positive terminal, branch off to each battery with a 1N4007 diode so that they see the circuit independently

Note

Harlan tried omitting the diode coming from the circuit, just using one going to each battery, and that did not work.

Ramifications

- The worst battery in the set does not become the weak link in the chain.
- No need to stop the circuit when rotating batteries
- No need to have the bank standing idle discharging while the battery from the input comes up to charge
- When the input battery discharges, the battery with the highest charge from the bank (not necessarily the one that has been there the longest), can be brought to the front end to run the circuit

NB. There is another trick that John will disclose to us in due time.

Reducing Bearing Friction Tip by Oneness

Part number for VXB recommended bearing: Sealed Ball Bearing R8-2RS 1/2"x 1 1/8"x 1/4"

1. Use an exacto blade to remove the bearings seals
2. Place the bearings in citrus degreaser bath. Every 10 minutes take them out and rense them with tap water. Put them back in to soak. Repeat the process three more times. The bearing should be clean of grease.
3. Dry them really well with a hairblower.
4. Add your lubricant of your choice: Xcellplus, or full synthtetic 5W20 motor oil.
5. Put the bearing seals back on by pressing them in.

CONCLUSION

A successful replication of the basic SSG is only the beginning of the learning process. The next step is to upgrade to more advanced setups involving multi-strand coils, and multiple stators. Applying this technology to other fields such as fuel cells is also a possibility.

REFERENCES

Bedini SG Peswiki Directory: http://peswiki.com/energy/Directory:Bedini_SG