

1.4A HIGH-SPEED OPTO-ISOLATED POWER MOSFET DRIVER

FEATURES

- Input to Output Isolation of 2.5kV RMS
- Operating Range 10V to 18V
- High Peak Output Current 1.4A Typ
- Short Delay Time <200 ns Typ
- Fast Switching on Outputs $T_R, T_F < 60\text{ns Typ}$
..... with $C_L = 1000\text{pF}$
- Low Power BiCMOS Design
- Undervoltage Lock-out with Hysteresis

APPLICATIONS

- Isolated Digital Line Driver
- Isolated Line Receiver
- "High-Side" Driver
- SMPS Control
- Motor Control
- Solid State Relays
- Off-Line Regulation/Control

UL File No: E151672

GENERAL DESCRIPTION

The TC4803/4 are BiCMOS optocoupled driver ICs for switching loads when electrical isolation is desired. Input drive current is converted to low impedance voltage drive with the ability to drive 1.4A peak current into a capacitive load of 1,000 pF with fast output rise and fall times. UV lockout circuitry forces the output to a "off" state when the input voltage drops below 7.8V. 0.4V of hysteresis prevents output toggling around the drop-out voltage. The output "off" state is high on TC4803 and low on TC4804.

For switching many loads in low-power regimes, these drivers, because they reduce shoot-through currents in the output stage, require significantly less power at higher frequencies, and can be helpful in meeting low-power budgets.

These devices are built using Teledyne Components' new Tough CMOS process and are capable of giving reliable service in the most demanding electrical environments.

They will not latch under normal conditions within their power and voltage ratings. All terminals are fully protected against up to 4 kV of electrostatic discharge.

ORDERING INFORMATION

Part No.	Package	Temperature Range
TC4803EPA	8-Pin PDIP	-40°C to +85°C
TC4804EPA	8-Pin PDIP	-40°C to +85°C

ABSOLUTE MAXIMUM RATINGS

Supply Voltage	+20V
Diode Signal Current Input	20mA
Maximum Chip Temperature	85°C
Storage Temperature Range	-55°C to +125°C
Lead Temperature (Soldering, 10 sec)	+300°C
Package Thermal Resistance	
PDIP $R_{\theta J-A}$	200°C/W
Operating Temperature Range	
Thermal Derating	5mW/°C above 25°C
Power Dissipation	300mW

Static-sensitive device. Unused devices must be stored in conductive material. Protect devices from static discharge and static fields. Stresses above those listed under Absolute Maximum Ratings may cause permanent damage to the device. These are stress ratings only and functional operation of the device at these or any other conditions above those indicated in the operational sections of the specifications is not implied. Exposure to Absolute Maximum Rating Conditions for extended periods may affect device reliability.

FUNCTIONAL DIAGRAM

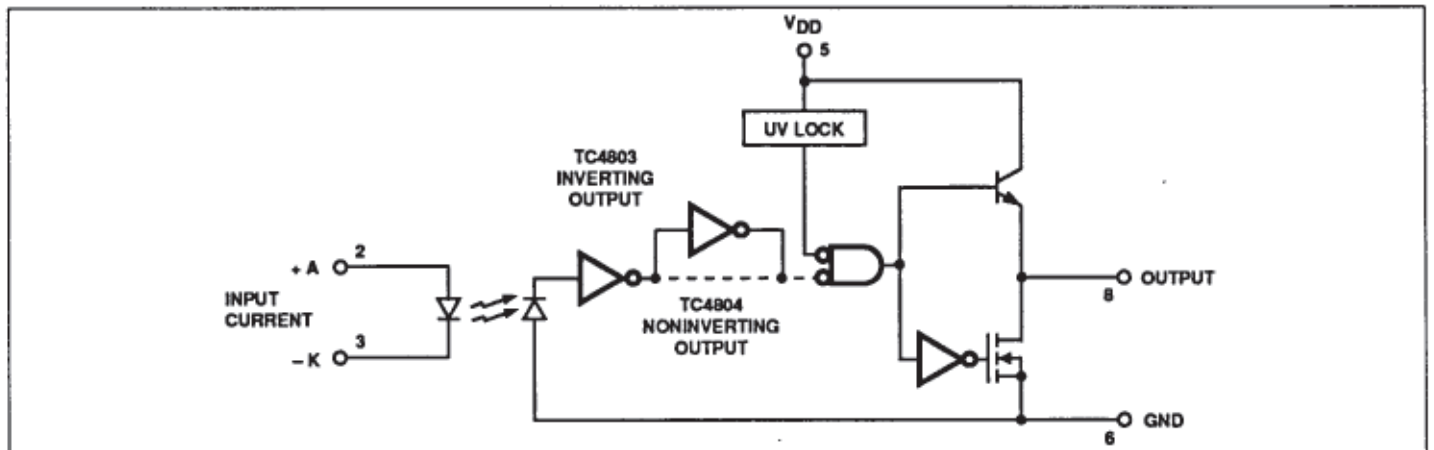

TC4803/04

ELECTRICAL CHARACTERISTICS:

Typical specifications measured at $T_A = +25^\circ\text{C}$ with $V_{DD} = 18\text{V}$, unless otherwise specified. Minimum and maximum specifications guaranteed over full temperature and power supply range.

Symbol	Parameter	Test Conditions	Min	Typ	Max	Unit
Input LED						
I_{FTH}	LED Forward Threshold Current (DC)		—	3.0	10	mA
I_{FMAX}	LED Forward Maximum Current (Continuous)		—	—	20	mA
V_F	LED Forward Voltage @ 10 mA Current		1.3	1.5	1.7	V
V_R	LED Reverse Voltage @ 50nA		6.0	—	—	V
	Isolation Voltage		2.5	—	—	kVRms
Output						
V_{OH}	High Output Voltage, $V_{DD} = 18\text{V}$, $I_{OUT} = 50\text{mA}$		16.3	16.9	—	V
V_{OL}	Low Output Voltage, $V_{DD} = 18\text{V}$, $I_{OUT} = 50\text{mA}$		—	.70	1.0	V
I_{PK}	Peak Output Current (Note 2) Source		—	1.4	—	A
	Sink			.5		A
I_{DC}	Continuous Output Current $V_{DD} = 18\text{V}$ (Source, sink)		100	—	—	mA
	DV/DT Input to Output Common Mode Transient Immunity		5	6	—	V/nS
Switching Time (Note 1)						
t_R	Rise Time	Figure 1	—	37	60	ns
t_F	Fall Time	Figure 1	—	40	80	ns
t_{D1}	Delay Time	Figure 1 (4803)	—	133	190	ns
t_{D2}	Delay Time	Figure 1 (4803)	—	200	260	ns
t_{D1}	Delay Time	Figure 1 (4804)	—	105	165	ns
t_{D2}	Delay Time	Figure 1 (4804)	—	143	225	ns
F_{MAX}	Maximum Operating Frequency		1	1.2	—	MHz
Power Supply						
I_{DD}	Power Supply Current	Output HIGH	—	4.0	8.0	mA
I_{DD}	Power Supply Current	Output LOW	—	3.0	5.0	mA
V_S	Start up threshold		—	8.7	10.0	V
V_{UV}	Drop-out threshold		7.5	8.4	—	V

NOTE: 1. Switching times guaranteed by design.
2. 1 μs , 1% duty cycle pulse input, output shorted to V_{DD} or GND.

PIN CONFIGURATION

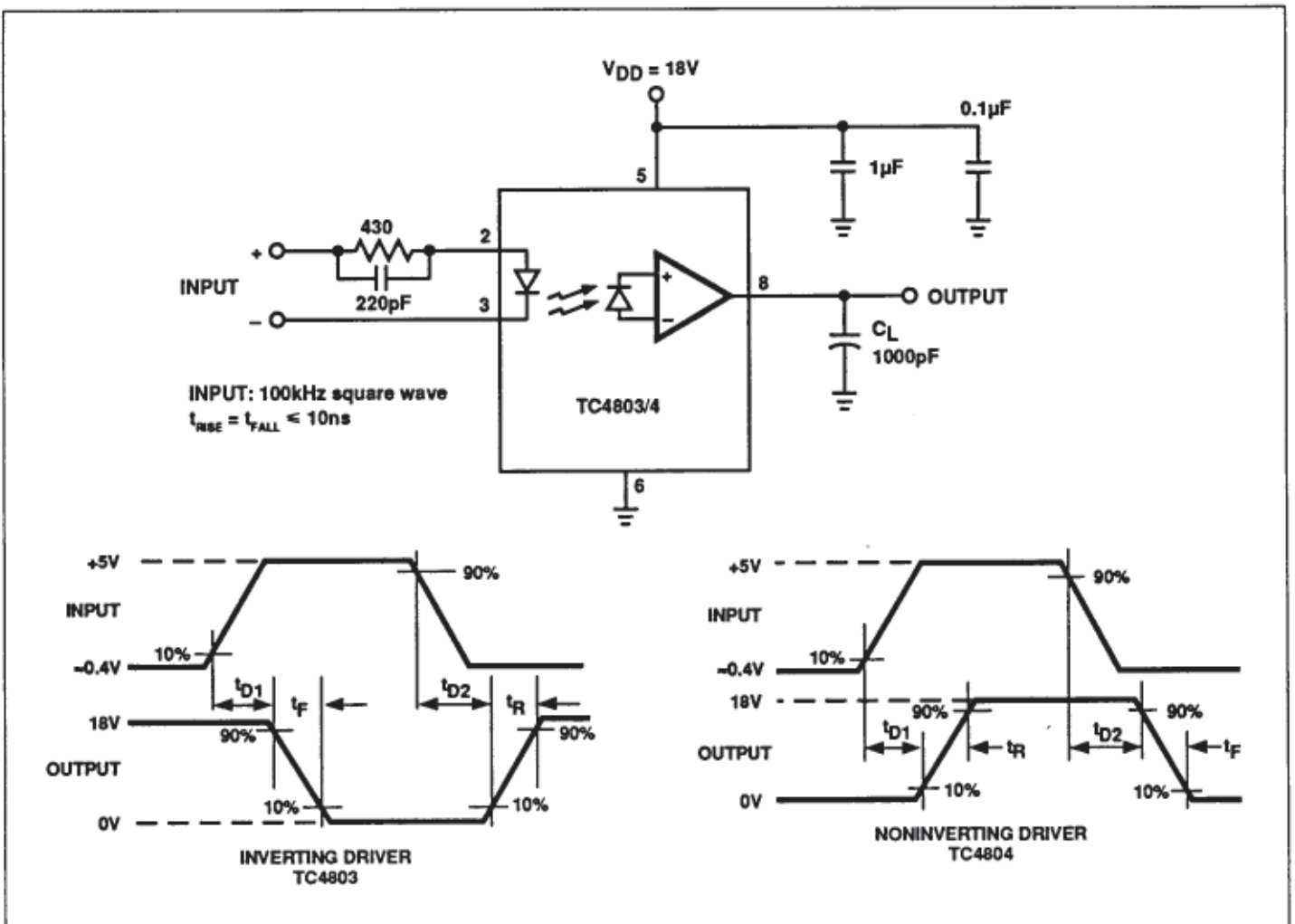
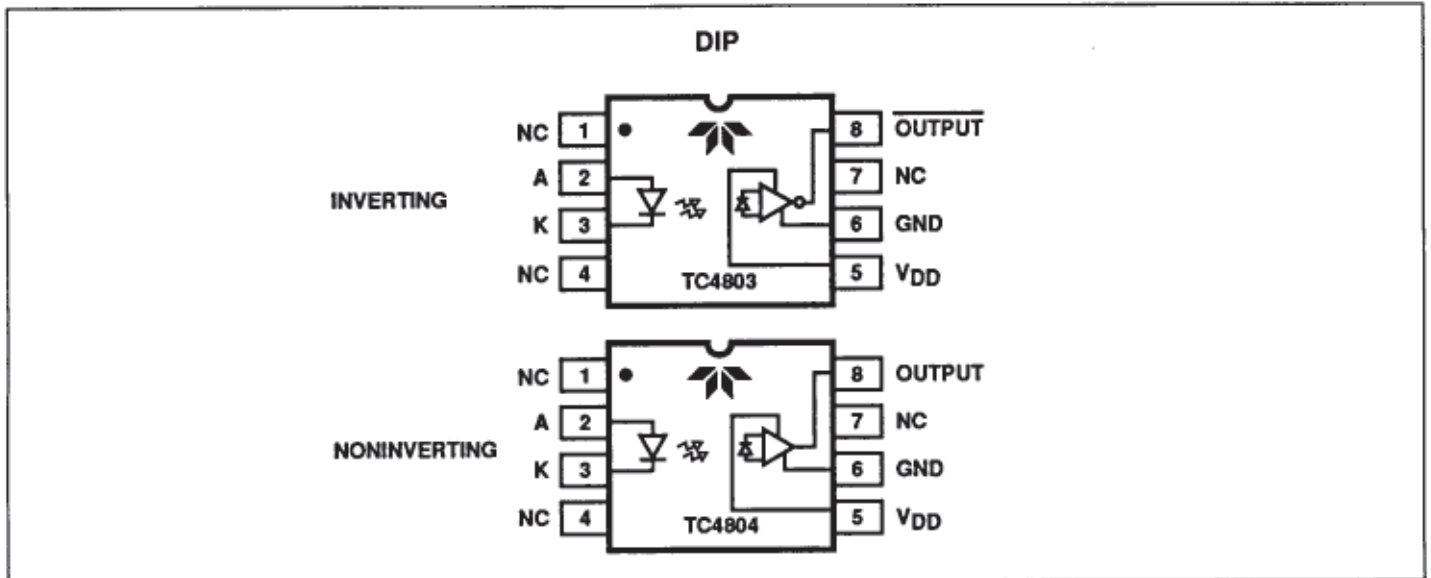
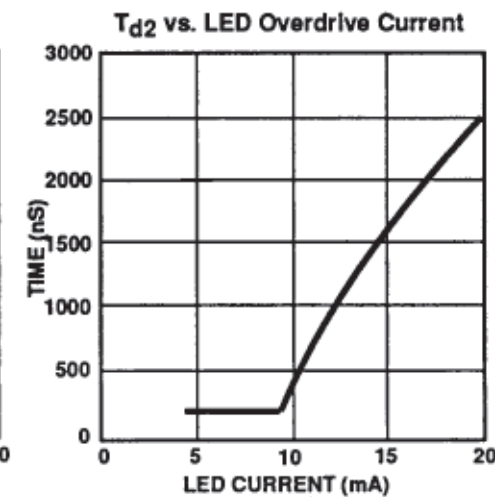
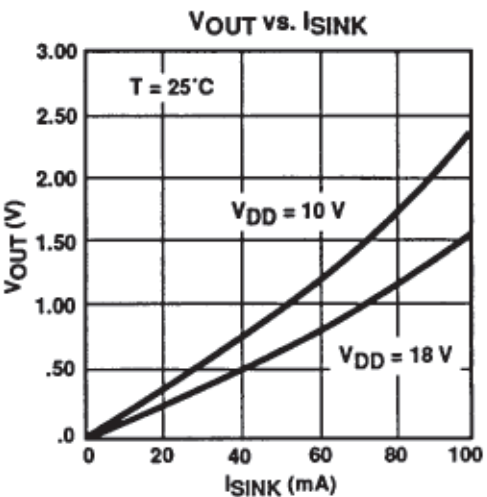
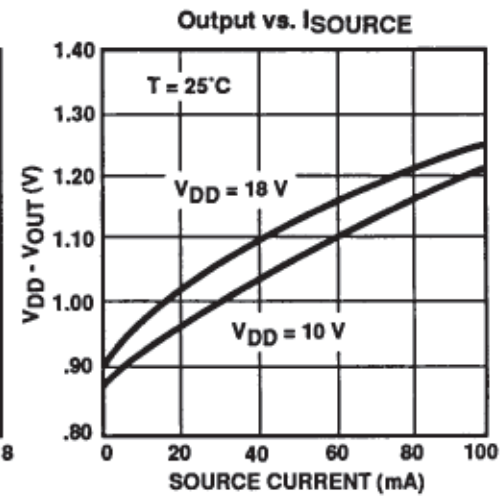
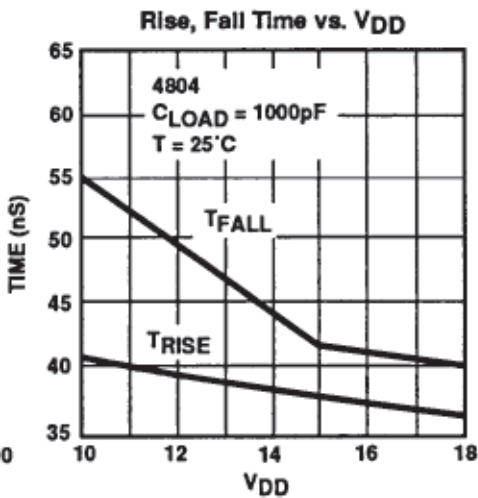
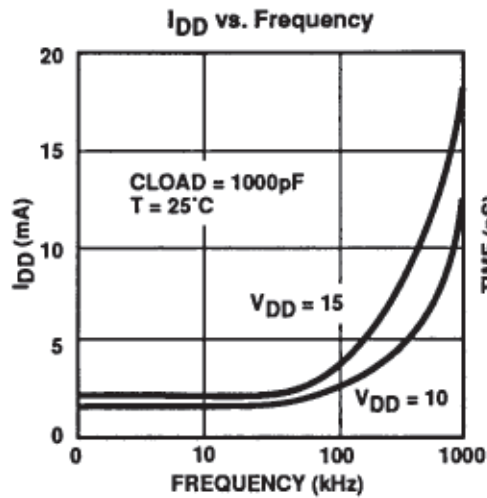
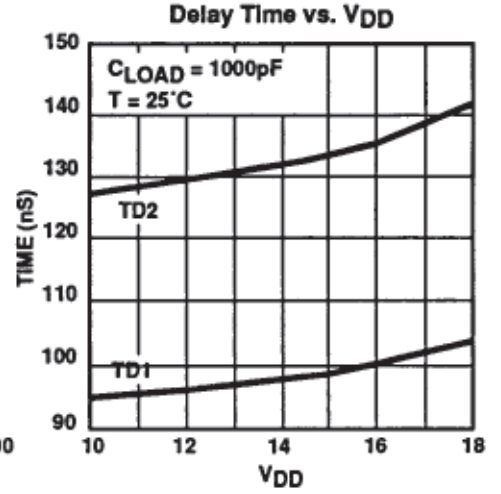
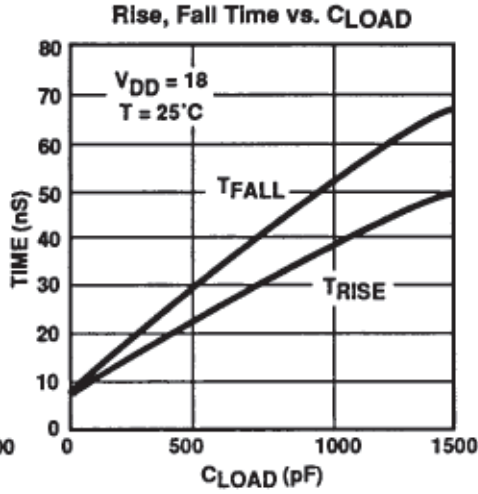
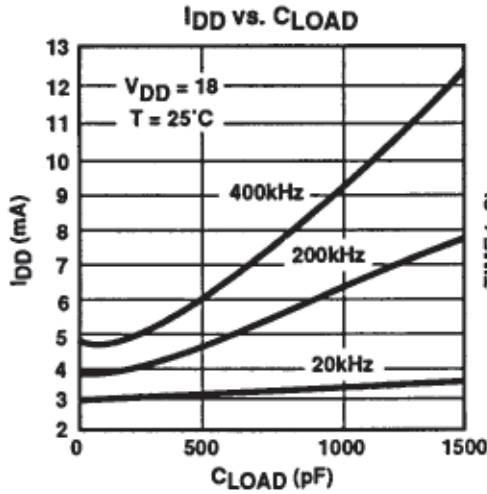

Figure 1 Switching Time Test Circuit

TC4803/04

TYPICAL CHARACTERISTICS CURVES



1.4A HIGH-SPEED OPTO-ISOLATED POWER MOSFET DRIVER

PRELIMINARY INFORMATION

TC4803/04

PACKAGE DIMENSIONS

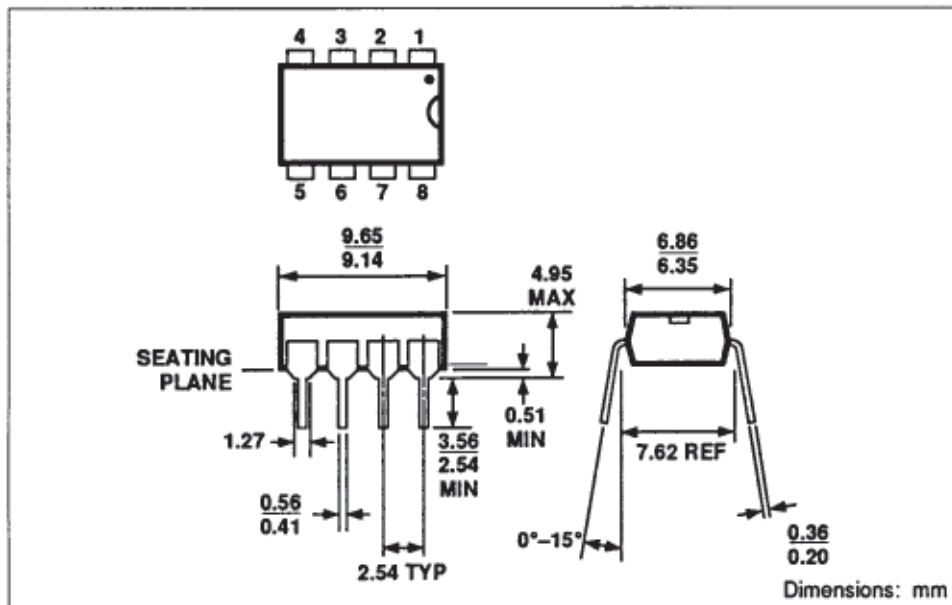

Domestic Sales Offices

Teledyne Components
1300 Terra Bella Avenue
P.O. Box 7267
Mountain View, CA 94039-7267
TEL: 415-968-9241
FAX: 415-967-1590

Teledyne Components
20 Walnut Street, 2nd Floor
Wellesley, MA 02181
TEL: 617-237-9696
FAX: 617-237-5612

Foreign Sales Offices

Teledyne Components
Abraham Lincoln Straße 38-42
6200 Wiesbaden
Germany
TEL: 49-611-76360
FAX: 49-611-701 239

Teledyne Components
The Harlequin Centre
Southhall Lane
Southhall
Middlesex, UB2 5NH
England
TEL: 44-1-571-9596
FAX: 44-1-571-9439
FAX: 44-1-571-8177