

[A Practical Guide to 'Free Energy' Devices](#)

Part D14: Last updated: 12th February 2008

Author: Patrick J. Kelly

Replication of Stanley Meyer's Demonstration Electrolyser

The material presented here is for information purposes only. Experimenting with hydrogen and/or a mixture of hydrogen and oxygen is highly dangerous and you do so entirely at your own risk. Neither Dave Lawton nor any other person connected with the preparation or display of this material recommends that you to do so and they disclaim any responsibility should you decide to do so against their advice.



Dave Lawton

The video of Dave Lawton's replication of Stanley Meyer's demonstration electrolyser (not his production electrolyser) seen at

<http://www.icubenetwork.com/files/watercar/non-commercial/dave/videos/Wfcrep.WMV>

has caused several people to ask for more details. The electrolysis shown in the video was driven by an alternator, shown here:



The field coil of the alternator is switched on and off by an FET transistor which is pulsed by a 555 timer circuit. This produces a composite waveform which produces an impressive rate of electrolysis using just tap water or rainwater with no additives whatsoever: The tubes in this replication are made of 316L grade stainless steel, five inches long although Stan's tubes were about three times that length. The outer tubes are 1 inch in diameter and the inner tubes 3/4 inch in diameter. As the wall thickness is 1/16 inch, the gap between them is between 1 mm and 2 mm. The inner pipes are held in place at each end by four rubber strips about one quarter of an inch long.

The container is made from two standard 4 inch diameter plastic drain down-pipe coupler fittings connected to each end of a piece of acrylic tube with PVC solvent cement. The acrylic tube was supplied already cut to size by Wake Plastics, 59 Twickenham Road, Isleworth, Middlesex TW7 6AR Telephone 0208-560-0928. The seamless stainless steel tubing was supplied by: <http://www.metalsontheweb.co.uk/asp/home.asp>

It is not necessary to use an alternator - Dave just did this as he was copying what Stan Meyer did. The circuit without the alternator produces gas at about the same rate and obviously draws less current as there is no alternator drive motor to be powered. A video of the non-alternator operation can be seen at the web site <http://www.free-energy-info.co.uk/WFCrep2.wmv>.

The electrolyser has an acrylic tube section to allow the electrolysis to be watched, as shown here:



The electrolysis takes place between each of the inner and outer tubes. The picture above shows the bubbles just starting to leave the tubes after the power is switched on. The picture below shows the situation a few seconds later when the whole of the area above the tubes is so full of bubbles that it becomes completely opaque:



The mounting rings for the tubes are like this:



And the 316L grade stainless steel, seamless tubes:



Here is the assembly ready to receive the inner tubes (wedged into place by small pieces of rubber):



The electrical connections to the pipes are via stainless steel wire running between stainless steel bolts tapped into the pipes and stainless steel bolts running through the base of the unit:

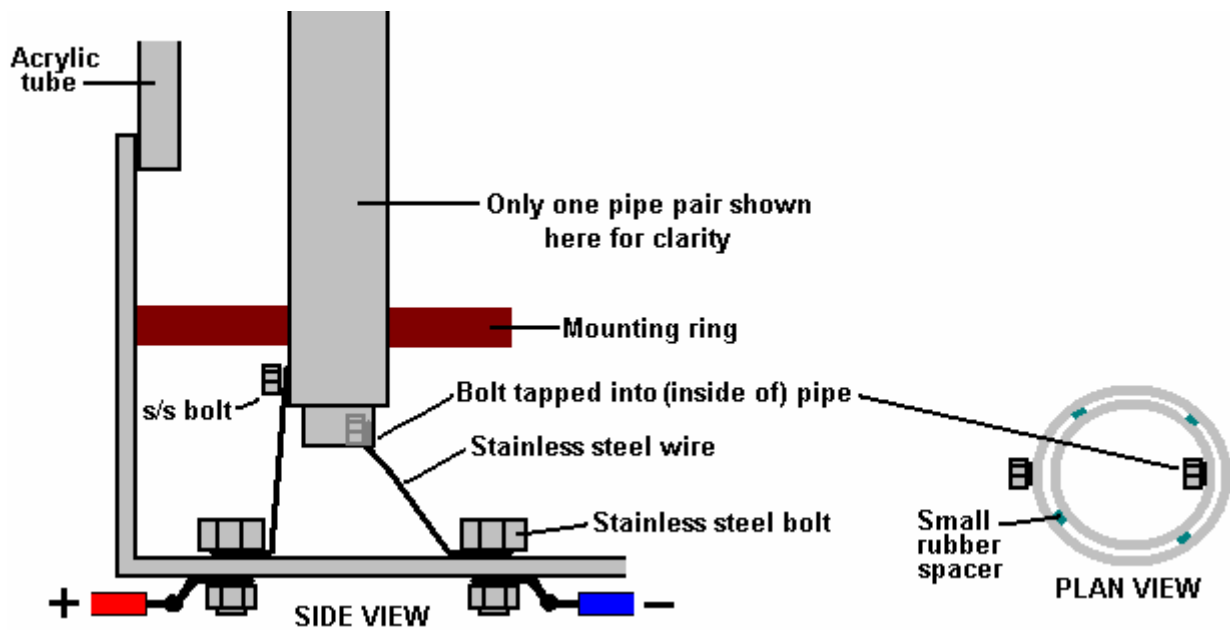

The bolts tapped into the inner tubes should be on the inside and the bottom of the two tubes aligned in spite of them being spread out as shown above. The diagram shows the inner connection on the outside, only for clarity. The bolts going through the base of the unit should be tapped in to give a tight fit and they should be sealed with Sikaflex bonding agent or some similar waterproofing material.

This electrolyser arrangement can be driven either via an alternator or by an electronic circuit. A suitable circuit for the alternator arrangement is:

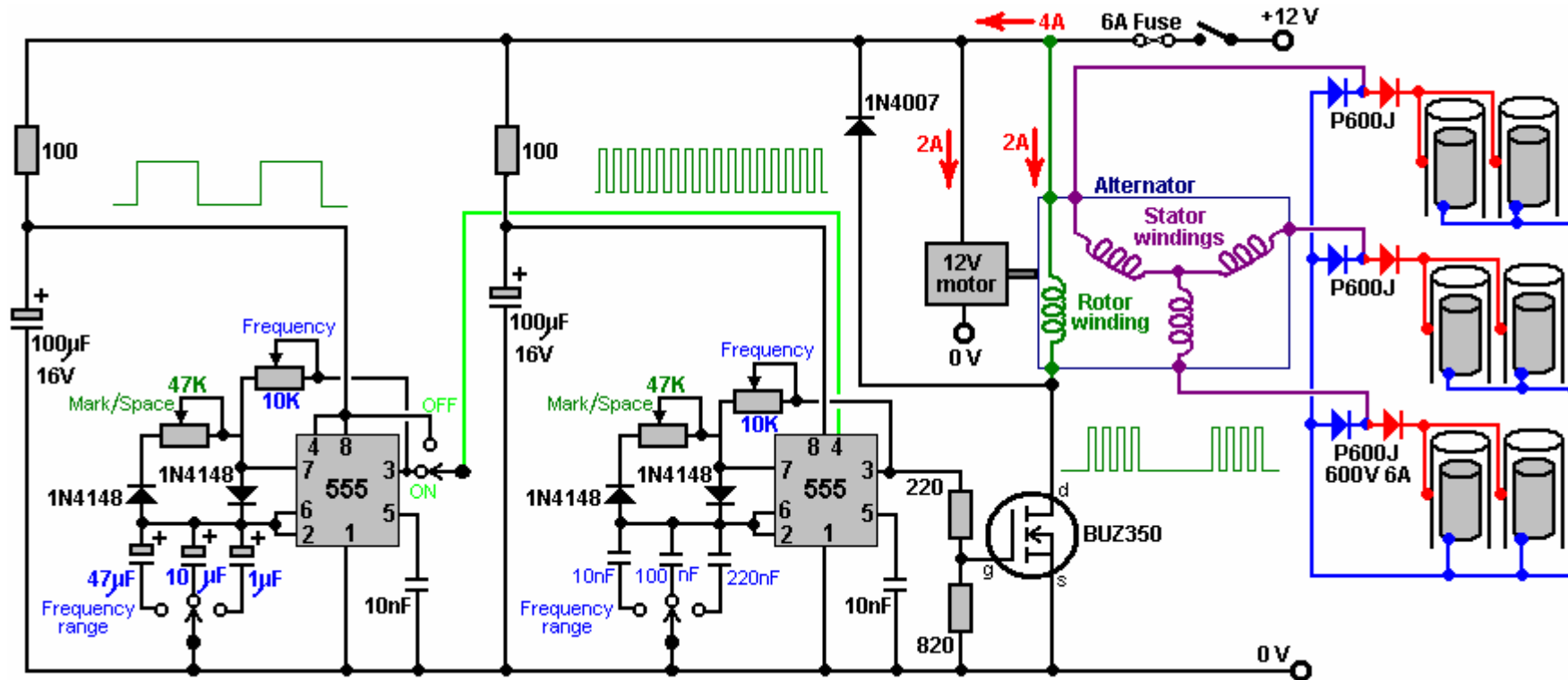

In this rather unusual circuit, the rotor winding of an alternator is pulsed via an oscillator circuit which has variable frequency and variable Mark/Space ratio and which can be gated on and off to produce the output waveform shown below the alternator in the circuit diagram. This is the waveform recommended by Stan Meyer. The oscillator circuit has a degree of supply de-coupling by the 100 ohm resistor feeding the 100 microfarad capacitor. This is to reduce voltage ripple coming along the +12 volt supply line, caused by the current pulses through the rotor winding.

The output arrangement feeding the pipe electrodes of the electrolyser is copied directly from Stan Meyer's circuit diagram. It is peculiar in that the positive pulses from each stator winding (shown in red in the circuit diagram) are applied to just two of the outer pipes, while the negative pulses (shown in blue in the circuit diagram) are applied to all six inner tubes. It is not obvious why Stan drew it that way, as you would expect all six outer tubes to be wired in parallel in the same way as the inner tubes are.

If the alternator does not have the windings taken to the outside of the casing, it is necessary to open the alternator, remove the internal regulator and diodes and pull out three leads from the ends of the stator windings. If you have an alternator which has the windings already accessible from the outside, then the stator winding connections are likely to be as shown here:

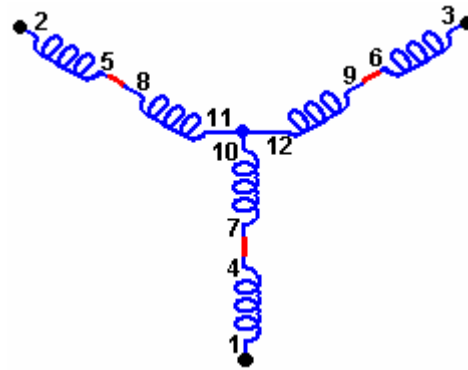

This same performance can be produced by the solid-state circuit on its own, as shown here:

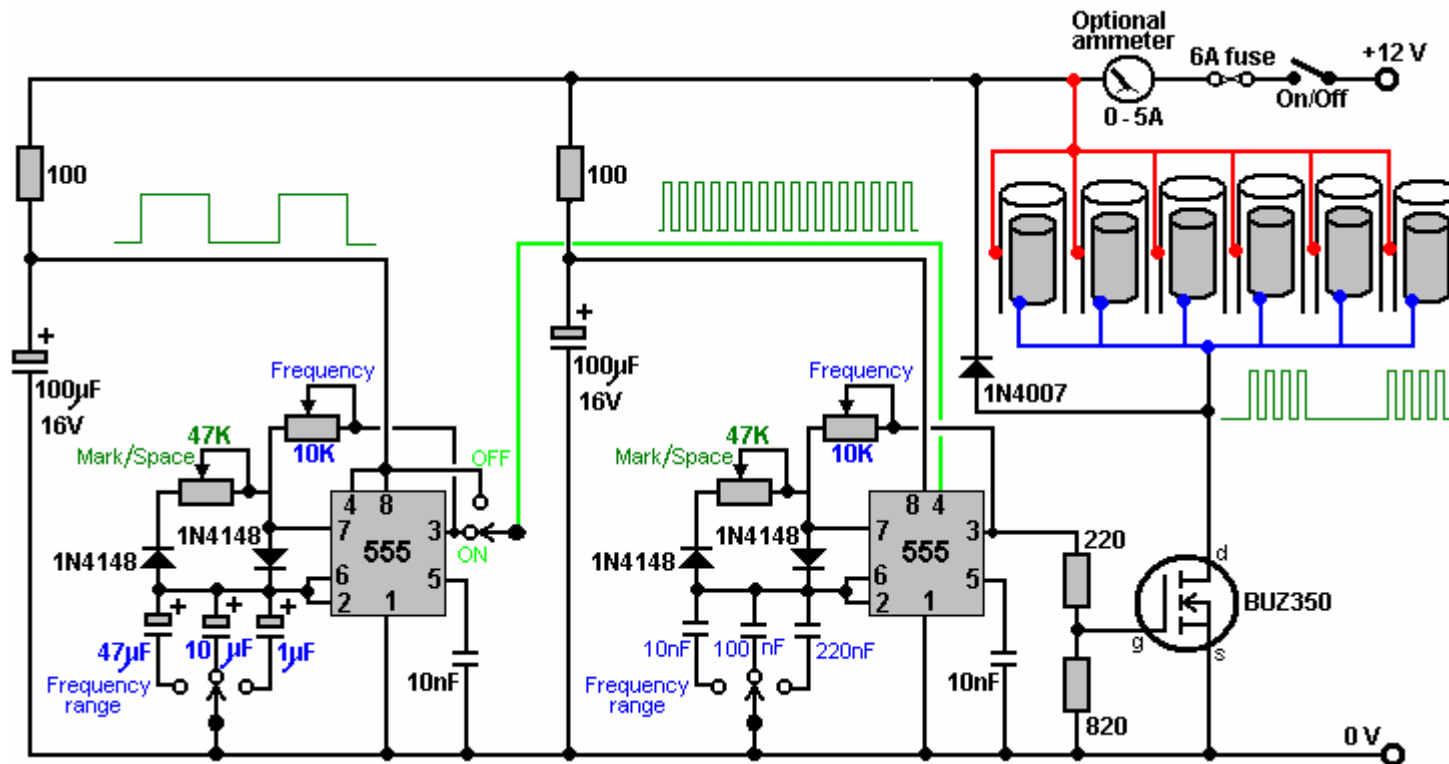

While the above circuits have been assessed as operating at about 300% of the Faraday assumed maximum efficiency, further experimentation has shown that the inductors used by Stanley Meyer form a very important role in raising the operating efficiency still higher. Dave has recently introduced two inductors, each wound with 100 turns of 22 SWG (21 AWG) enamelled copper wire on a 9 mm (3/8") diameter ferrite rod 25 mm (1 inch) long or longer, or on a ferrite toroid, though that is more difficult to wind. These coils are wound at the same time using two wires side by side. The improved circuit is now:

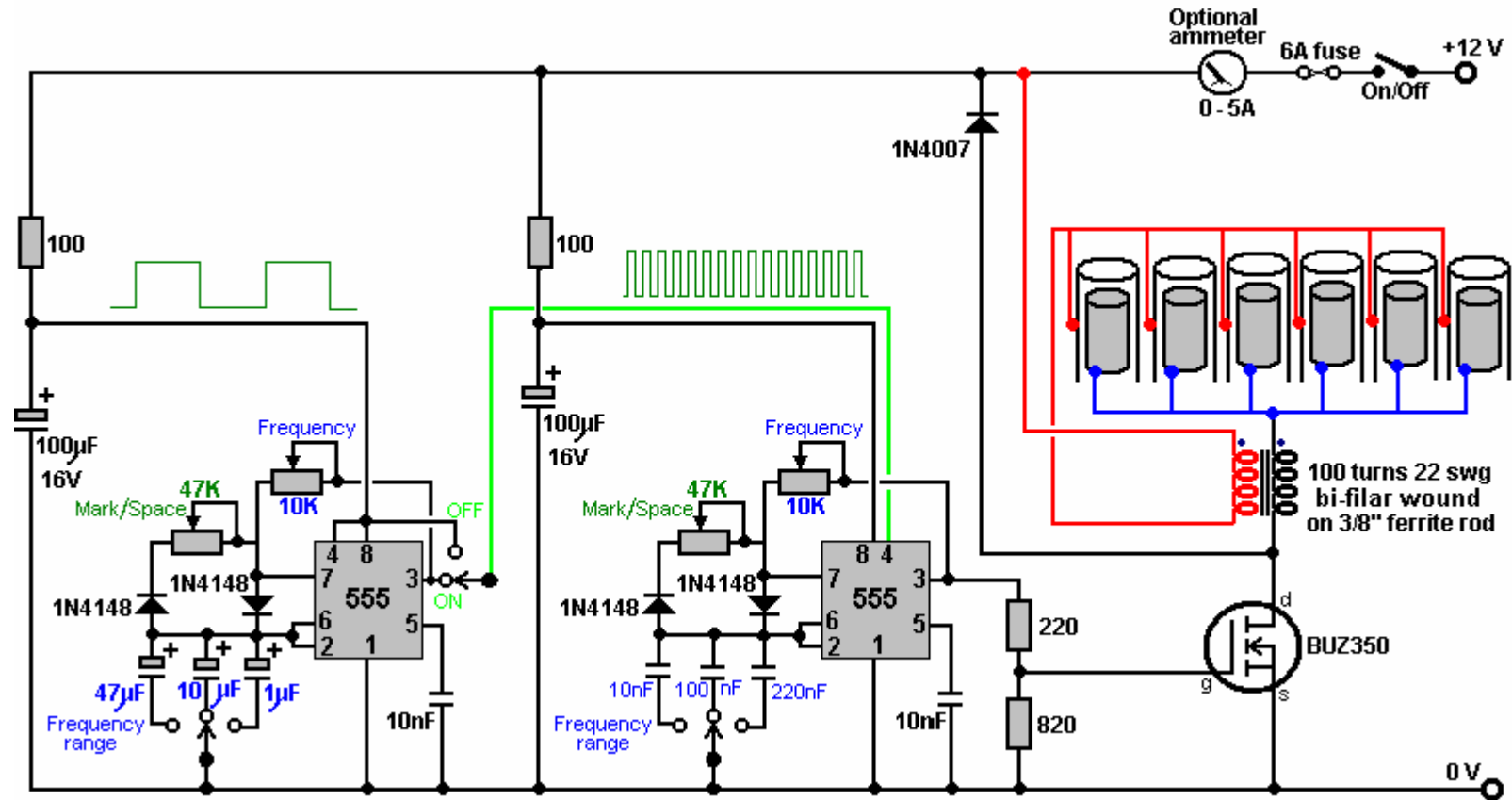

Circuit operation:

Each NE555 timer chip is placed in an oscillator circuit which has both variable pulse rate (“frequency”) and variable Mark/Space ratio which does not affect the frequency. These oscillator circuits also have three frequency ranges which can be selected by a rotary switch. The variable resistors each have a 100 ohm resistor in series with them so that their combined resistance cannot fall below 100 ohms. Each oscillator circuit has its supply de-coupled by placing a 100 microfarad capacitor across the supply rails and feeding the capacitor through a 100 ohm resistor. This has the effect of reducing any pulsing being carried along the battery connections to affect the adjoining circuit.

The first NE555 circuit has fairly large capacitors which give it comparatively slow pulses, as represented by the waveform shown above it. The output from that NE555 is on pin 3 and can be switched to feed the waveform to pin 4 of the second NE555 timer. This gates the second, higher frequency oscillator On and Off to produce the output waveform shown just below the pipe electrodes. The switch at pin 3 of the first NE555 allows the gating to be switched off, which causes the output waveform to be just a straight square wave of variable frequency and Mark/Space ratio.

The output voltage from pin 3 of the second NE555 chip is reduced by the 220 ohm / 820 ohm resistor combination. The transistor acts as a current amplifier, capable of providing several amps to the electrodes. The 1N4007 diode is included to protect the MOSFET should it be decided at a later date to introduce either a coil (“inductor”) or a transformer in the output coming from the MOSFET, as sudden switching off of a current through either of these could briefly pull the ‘drain’ connection a long way below the 0 Volt line and damage the MOSFET, but the 1N4007 diode switches on and prevents this from happening by clamping the drain voltage to -0.7 volts if the drain is driven to a negative voltage.

The BUZ350 MOSFET has a current rating of 22 amps so it will run cool in this application. However, it is worth mounting it on an aluminium plate which will act both as the mounting and a heat sink. The current draw in this arrangement is particularly interesting. With just one tube in place, the current draw is about one amp. When a second tube is added, the current increases by less than half an amp. When the third is added, the total current is under two amps. The fourth and fifth tubes add about 100 milliamps each and the sixth tube causes almost no increase in current at all. This suggests that the efficiency could be raised further by adding a large number of additional tubes, and as the gas is produced inside the tubes and the outer tubes are connected electrically, they could probably be bundled together.

Although the current is not particularly high, a six amp circuit-breaker, or fuse, should be placed between the power supply and the circuit, to protect against accidental short-circuits. If a unit like this is to be mounted in a vehicle, then it is **essential** that the power supply is arranged so that the electrolyser is disconnected if the engine is switched off. Passing the electrical power through a relay which is powered via the ignition switch is a good solution for this. It is also **vital** that at least one bubbler is placed between the electrolyser and the engine, to give some protection if the gas should get ignited by an engine malfunction. It is also a good idea for the bubbler(s) lid to be a tight push fit so that it can pop off in the event of an explosion, and so further limit the effect of an accident.

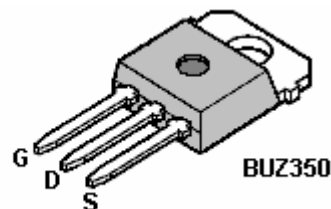
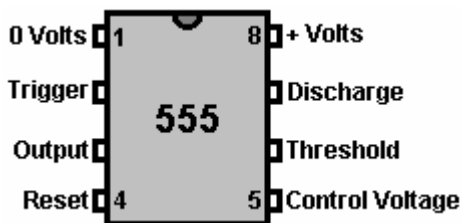

A possible component layout is shown here:

● = Track cut on underside of the board

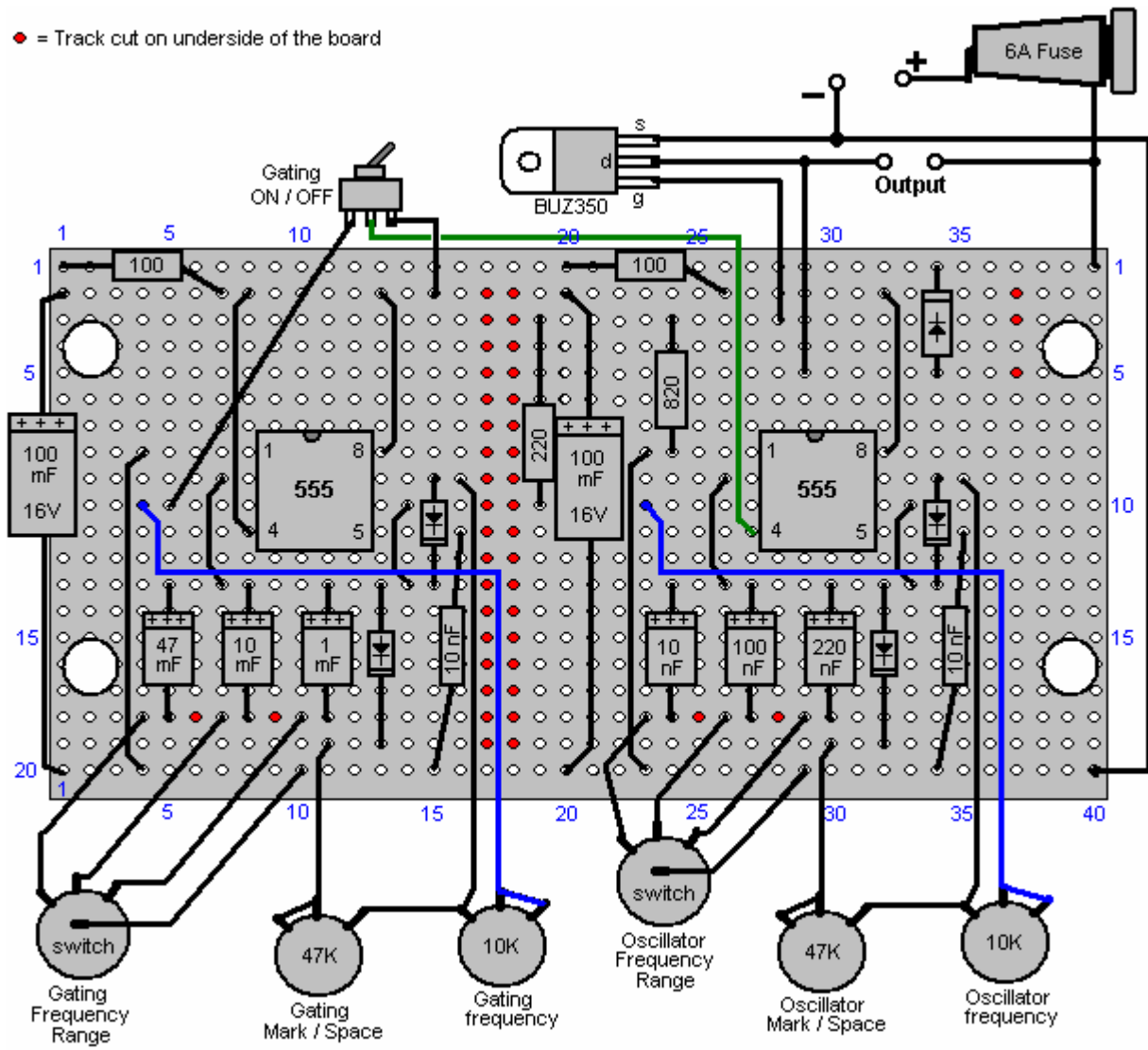

The underside of the stripboard is shown here:

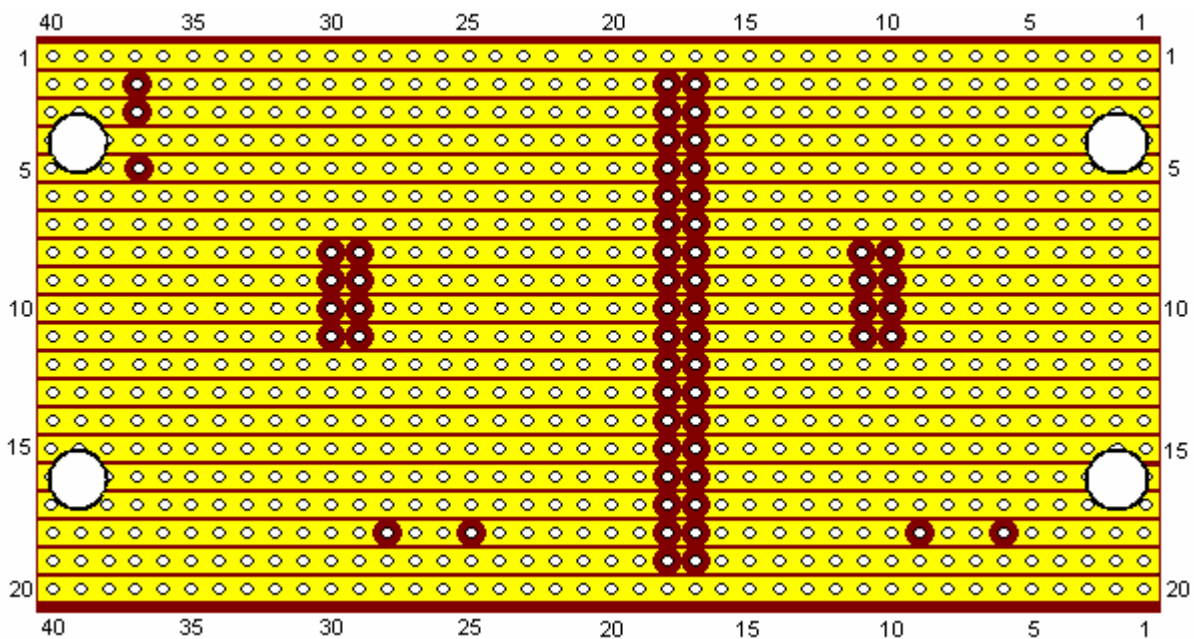

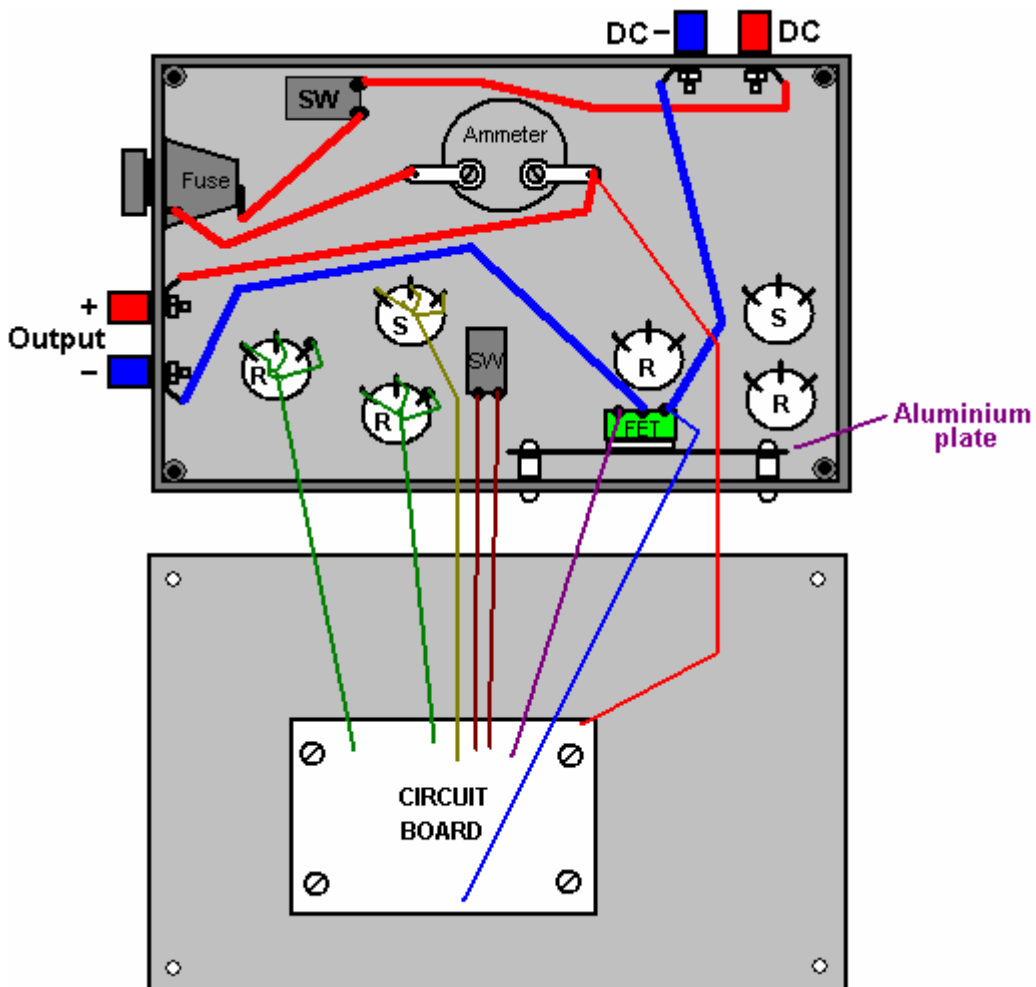

Component	Quantity	Description	Comment
100 ohm resistors 0.25 watt	2	Bands: Brown, Black, Brown	
220 ohm resistor 0.25 watt	1	Bands: Red, Red, Brown	
820 ohm resistor 0.25 watt	1	Bands: Gray, Red, Brown	
100 mF 16V capacitor	2	Electrolytic	
47mF 16V capacitor	1	Electrolytic	
10 mF 16V capacitor	1	Electrolytic	
1 mF 16 V capacitor	1	Electrolytic	
220 nF capacitor (0.22 mF)	1	Ceramic or polyester	
100 nF capacitor (0.1 mF)	1	Ceramic or polyester	
10 nF capacitor (0.01 mF)	3	Ceramic or polyester	
1N4148 diodes	4		
1N4007 diode	1		FET protection
NE555 timer chip	2		
BUZ350 MOSFET	1	Or any 200V 20A n-channel MOSFET	
47K variable resistors	2	Standard carbon track	Could be screw track
10K variable resistors	2	Standard carbon track	Could be screw track
4-pole, 3-way switches	2	Wafer type	Frequency range
1-pole changeover switch	1	Toggle type, possibly sub-miniature	Any style will do
1-pole 1-throw switch	1	Toggle type rated at 10 amps	Overall ON / OFF switch
Fuse holder	1	Enclosed type or a 6A circuit breaker	Short-circuit protection
Veroboard	1	20 strips, 40 holes, 0.1 inch matrix	Parallel copper strips
8-pin DIL IC sockets	2	Black plastic, high or low profile	Protects the 555 ICs
Wire terminals	4	Ideally two red and two black	Power lead connectors
Plastic box	1	Injection moulded with screw-down lid	
Mounting nuts, bolts and pillars	8	Hardware for 8 insulated pillar mounts	For board and heatsink
Aluminium sheet	1	About 4 inch x 2 inch	MOSFET heatsink
Rubber or plastic feet	4	Any small adhesive feet	Underside of case
Knobs for variable resistors etc.	6	1/4 inch shaft, large diameter	Marked skirt variety
Ammeter	1	Optional item, 0 to 5A or similar	
Ferrite rod 1-inch long or longer	1	For construction of the inductors	bi-filar wound
22 SWG (21 AWG) wire	1 reel	Enamelled copper wire, 2 oz. reel	
Sundry connecting wire	4 m	Various sizes	

As mentioned earlier, it is absolutely vital that every precaution be taken to avoid an explosion. The “hydroxy” gas produced by the electrolysis of water is mainly hydrogen gas and oxygen gas mixed together in the ideal proportions for them to recombine to form water again. That happens when the gasses are lit, and as the flame front of the ignition is about 1,000 times faster than the flame front when petroleum vapour is ignited, standard flash-back protection devices just do not work. The best protection device is a bubbler which is a simple container which feeds the gas up through a column of water.

It is also a good idea to use a pressure-activated switch which disconnects the power to the electronics if the gas pressure exceeds, say, five pounds per square inch, as shown here:

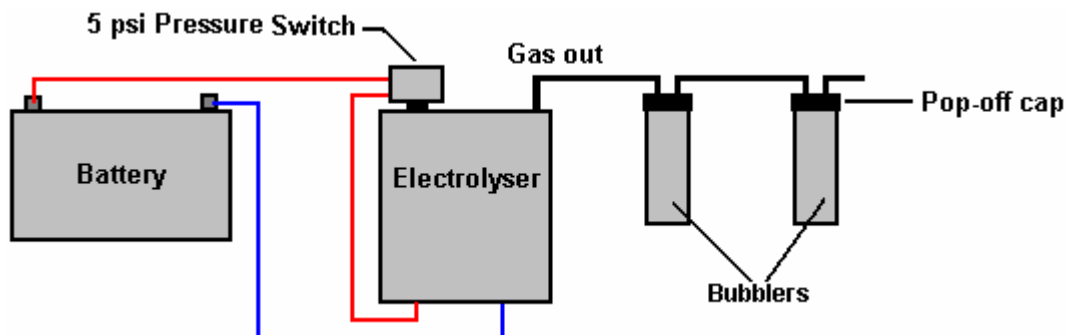

If it is intended to use the electrolyser to feed an internal combustion engine, then the timing of the spark will need to be adjusted, and if the engine is very small and has a waste spark, then that needs to be dealt with as well. These details are covered in the “D9.pdf” document which forms part of this set of documents.

Dave, who built this replication, suggests various improvements. Firstly, Stan Meyer used a larger number of tubes of greater length. Both of those two factors should increase the gas production considerably. Secondly, careful examination of video of Stan's demonstrations shows that the outer tubes which he used had a rectangular slot cut in the top of each tube:

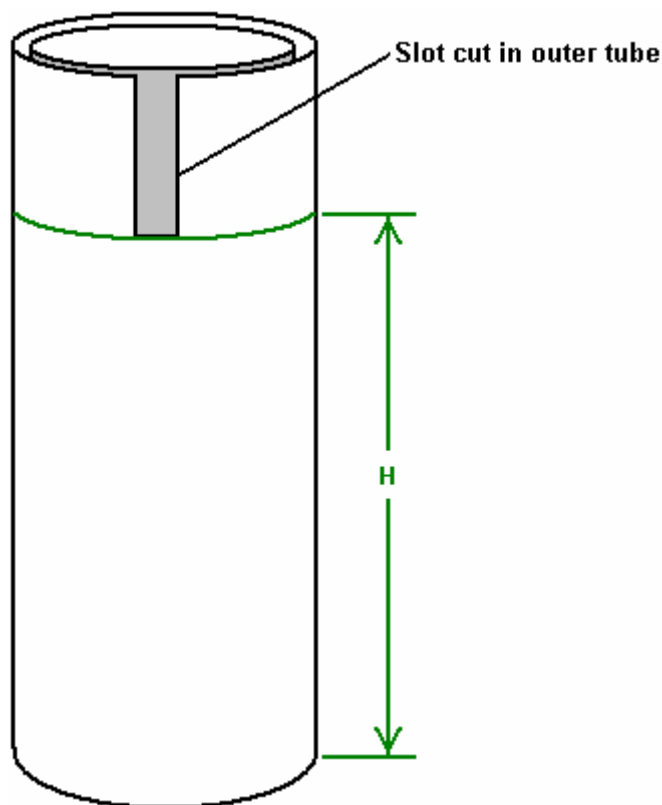

Some organ pipes are fine-tuned by cutting slots like this in the top of the pipe, to raise its pitch, which is its frequency of vibration. As they are thinner, the inner pipes in the Meyer cell will resonate at a higher frequency than the outer pipes. It therefore seems probable that the slots cut by Stan are to raise the resonant frequency of the larger pipes, to match the resonant frequency of the inner pipes. If you want to do that, hanging the inner tube up on a piece of thread and tapping it, will produce a sound at the resonant pitch of the pipe. Cutting a slot in one outer pipe, suspending it on a piece of thread and tapping it, will allow the pitch of the two pipes to be compared. When one outer pipe has been matched to your satisfaction, then a slot of exactly the same dimensions will bring the other outer pipes to the same resonant pitch. It has not been proved, but it has been suggested that only the part of the outer pipe which is below the slot, actually resonates. That is the part marked as "H" in the diagram above. It is also suggested that the pipes will resonate at the same frequency if the area of the inside face of the outer pipe ("H" x the inner circumference) exactly matches the area of the outer surface of the inner pipe. It should be remembered that as all of the pipe pairs will be resonated with a single signal, that each pipe pair needs to resonate at the same frequency as all the other pipe pairs.

It is said that Stan ran his Volkswagen car for four years, using just the gas from four of these units.

A very important part of the cell build is the conditioning of the electrode tubes, using tap water. This is done as follows:

1. Do not use any resistance on the negative side of the power supply when conditioning the pipes.
2. Start at 0.5 Amps on the signal generator and after 25 minutes, switch off for 30 minutes
3. Then apply 1.0 Amps for 20 minutes and then stop for 30 minutes.
4. Then apply 1.5 Amps for 15 minutes and then stop for 20 minutes.
5. Then apply 2.0 Amps for 10 minutes and afterwards stop for 20 minutes.

6. Go to 2.5 Amps for 5 minutes and stop for 15 minutes.

7. Go to 3.0 Amps for 120 to 150 seconds. You need to check if the cell is getting hot...if it is you need to reduce the time.

After the seven steps above, let the cell stand for at least an hour before you start all over again.

You will see hardly any gas generation in the early stages of this conditioning process, but a lot of brown muck will be generated. Initially, change the water after every cycle, but **do not** touch the tubes with bare hands. If the ends of the tubes need to have muck cleaned off them, then use a brush but do not touch the electrodes!! If the brown muck is left in the water during the next cycle, it causes the water to heat up and you need to avoid this.

Over a period of time, there is a reduction in the amount of the brown stuff produced and at some point, the pipes won't make any brown stuff at all. You will be getting very good gas generation by now. A whitish powdery coat will have developed on the surfaces of the electrodes. Never touch the pipes with bare hands once this coating has developed.

Important: Do the conditioning in a well-ventilated area, or alternatively, close the top of the cell and vent the gas out into the open. During this process, the cell is left on for quite some time, so even a very low rate of gas production can accumulate a serious amount of gas which would be a hazard if left to collect in a small space.

Further Developments

When producing hydroxy gas from water, it is not possible to exceed the Faraday maximum unless additional energy is being drawn in from the surrounding environment. As this cell runs cold and has substantial gas output, there is every indication that when it is running, it is drawing in this extra energy.

This idea is supported by the fact that one of the key methods of tapping this extra energy is by producing a train of very sharply rising and sharply falling electrical pulses. This is exactly the objective of Dave's circuit, so it would not be too surprising if that effect were happening.

The additional energy being accessed is sometimes referred to as "cold" electricity, which has very different characteristics to normal conventional electricity. Where normal electrical losses cause local heating as a by-product, "cold" electricity has exactly the opposite effect, and where a normal electrical loss would take place, an extra inflow of useful "cold" energy enters the circuit from outside. This flow causes the temperature of the circuitry to drop, instead of increase, which is why it is called "cold" electricity.

This remarkable occurrence has the most unusual effect of actually reducing the amount of conventional power needed to drive the circuit, if the output load is increased. So, increasing the load powered by the circuit causes additional energy to flow in from the environment, powering the extra load and as well, helping to drive the original circuit. This seems very strange, but then, "cold" electricity operates in an entirely different way to our familiar conventional electricity, and it has its own set of unfamiliar rules, which are generally the reverse of what we are used to.

To test his cell system further, Dave connected an extra load across the electrodes of his cell. As the inductors connected each side of the cell generate very high-value, sharp voltage spikes, Dave connected two large value capacitors (83,000 microfarad, 50-volt) across the cell as well. The load was a 10-watt light bulb which shines brightly, and interestingly, the current draw of the circuit goes down rather than up, in spite of the extra output power. The gas production rate appears undiminished.

This is the alteration to that part of the circuit which was used:

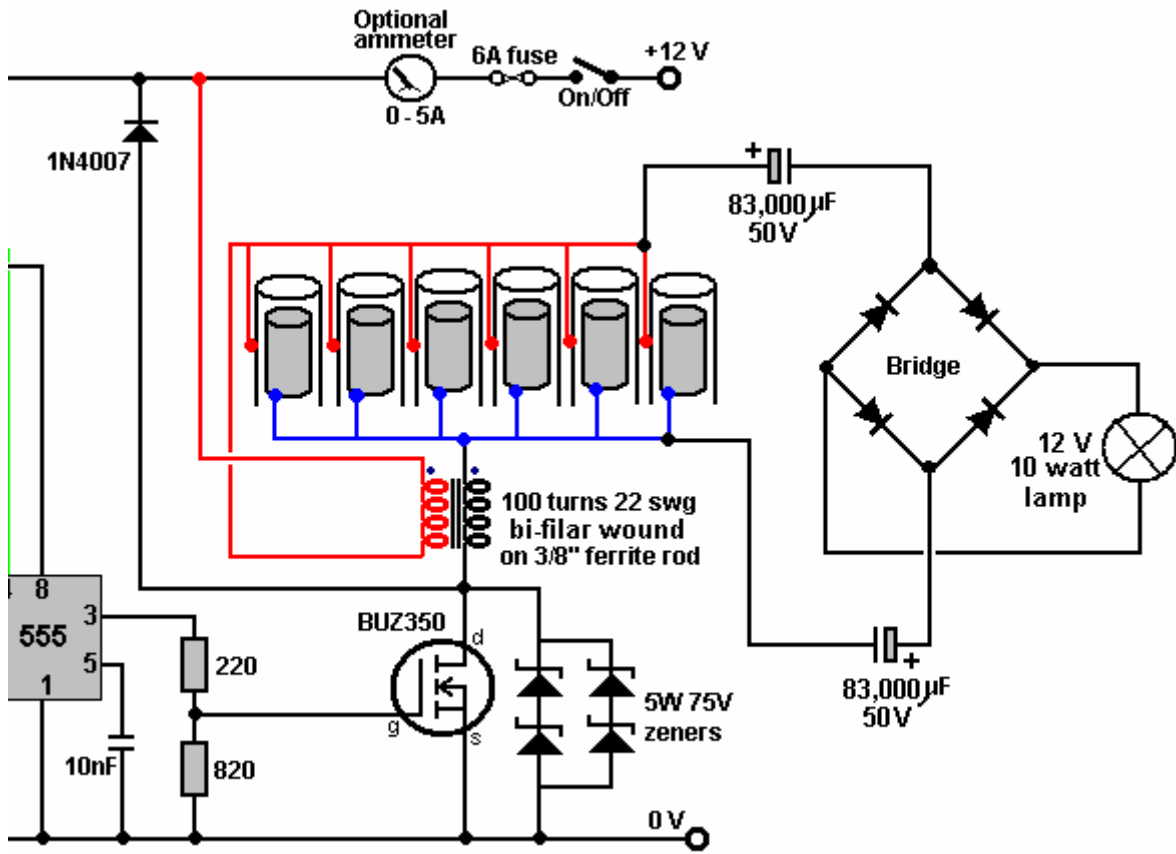

It has also been suggested that it would be advisable to protect the output FET against damage caused by accidental short-circuiting of wires, by connecting what is effectively a 150-volt, 10 watt zener diode across it as shown in the above diagram. While this is not necessary for the correct operation of the circuit, it is helpful in cases where accidents occur during repeated testing and modification of the cell components.