

(19) World Intellectual Property Organization
International Bureau



(43) International Publication Date
6 April 2006 (06.04.2006)

PCT

(10) International Publication Number
WO 2006/035419 A1

(51) International Patent Classification⁷: **H01F 7/02**

(21) International Application Number:
PCT/IE2005/000107

(22) International Filing Date:
27 September 2005 (27.09.2005)

(25) Filing Language: English

(26) Publication Language: English

(30) Priority Data:
60/613,565 27 September 2004 (27.09.2004) US

(71) Applicant (for all designated States except US): **STEORN LIMITED** [IE/IE]; Docklands Innovation Park, East Wall Road, Dublin 3 (IE).

(72) Inventors; and

(75) Inventors/Applicants (for US only): **MCCARTHY, Shaun, David** [IE/IE]; 6 Gilford Avenue, Sandymount, Dublin 4 (IE). **SIMPSON, Alan** [IE/IE]; 16 Moreen Walk, Sandyford, Dublin 16 (IE). **DALY, Michael, Andrew** [IE/IE]; 4 Orchard View, Delgany Wood, Delgany, County Wicklow (IE).

(74) Agent: **FF GORMAN & CO.**; 15 Clanwilliam Square, Dublin 2 (IE).

(81) Designated States (unless otherwise indicated, for every kind of national protection available): AE, AG, AL, AM, AT, AU, AZ, BA, BB, BG, BR, BW, BY, BZ, CA, CH, CN, CO, CR, CU, CZ, DE, DK, DM, DZ, EC, EE, EG, ES, FI, GB, GD, GE, GH, GM, HR, HU, ID, IL, IN, IS, JP, KE, KG, KM, KP, KR, KZ, LC, LK, LR, LS, LT, LU, LV, LY, MA, MD, MG, MK, MN, MW, MX, MZ, NA, NG, NI, NO, NZ, OM, PG, PH, PL, PT, RO, RU, SC, SD, SE, SG, SK, SL, SM, SY, TJ, TM, TN, TR, TT, TZ, UA, UG, US, UZ, VC, VN, YU, ZA, ZM, ZW.

(84) Designated States (unless otherwise indicated, for every kind of regional protection available): ARIPO (BW, GH, GM, KE, LS, MW, MZ, NA, SD, SL, SZ, TZ, UG, ZM, ZW), Eurasian (AM, AZ, BY, KG, KZ, MD, RU, TJ, TM), European (AT, BE, BG, CH, CY, CZ, DE, DK, EE, ES, FI, FR, GB, GR, HU, IE, IS, IT, LT, LU, LV, MC, NL, PL, PT, RO, SE, SI, SK, TR), OAPI (BF, BJ, CF, CG, CI, CM, GA, GN, GQ, GW, ML, MR, NE, SN, TD, TG).

Declaration under Rule 4.17:

— as to applicant's entitlement to apply for and be granted a patent (Rule 4.17(ii))

Published:

— with international search report

For two-letter codes and other abbreviations, refer to the "Guidance Notes on Codes and Abbreviations" appearing at the beginning of each regular issue of the PCT Gazette.

(54) Title: **LOW ENERGY MAGNETIC ACTUATOR**

(57) Abstract: A low energy magnet actuator allows magnetic fields to be turned on and off using a small amount of energy. The magnetic actuator according to the invention generally includes a base (14) suitable for the support of a plurality of magnets (10,12). An actuatable shield (18) is positioned in relation to the plurality of magnets (10,12) so that it effectively blocks the magnetic field when it is positioned over at least one of the magnets (10,12). The magnetic fields of the plurality of magnets (10,12) interact in a manner that allows low energy actuation of the shield (18).

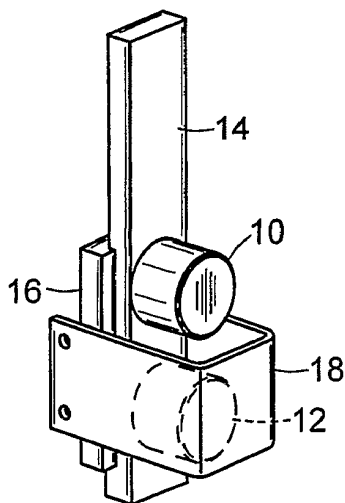

WO 2006/035419 A1

“Low Energy Magnetic Actuator”

FIELD OF THE INVENTION

The present invention relates to a magnetic actuating apparatus.

5

BACKGROUND OF THE INVENTION

Electromagnets are commonly used where there is a requirement for a magnetic field to be actuated (turned on/off).

10 An electromagnet achieves this effect by providing (generating) a magnetic field while electrical current is applied to it. To turn off the field the current is no longer applied to the electromagnet.

The use of electromagnets to effectuate magnetic fields suffers from one major
15 drawback - the electromagnet requires a relatively large amount of electrical energy to operate.

Many techniques are being used to reduce the amount of external energy that an electromagnet requires. Primarily these techniques relate to the efficiency of the
20 electromagnet and its components.

SUMMARY OF THE INVENTION

A low energy magnet actuator allows magnetic fields to be turned on and off using a small amount of energy. The magnetic actuator according to the invention generally
25 includes a base suitable for the support of a plurality of magnets. An actuatable shield is positioned in relation to the plurality of magnets so that it effectively blocks the magnetic field when it is positioned over at least one of the magnets. The magnetic fields of the plurality of magnets interact in a manner that allows low energy actuation of the shield.

In one illustrative embodiment of an actuator according to the invention, the base supports a first magnet mounted to the base in a first position. A second magnet is supported by the base in a second position relative to the first magnet. A shield is positioned relative to the first and second magnets in a configuration that enables the movement of the shield between two known positions. In this illustrative embodiment, each magnet is of similar field strength and the field that radiates from the ends are of the same polarity. The shield is of a thickness that effectively blocks the emitted magnetic field when positioned over one or the other of the magnets. The magnetic fields of the two magnets interact in a manner that allows for the low-energy movement of the shield. The exposed magnetic field may be used to perform work (e.g. interact with other magnetic fields to move an object).

Advantages of the actuator according to the invention include low energy actuation of the shield in a manner that yields motion or actuation that is highly efficient. The highly efficient actuation of the shield results in movement that can perform work in a highly efficient manner.

BRIEF DESCRIPTION OF THE DRAWINGS

The foregoing, and other features and advantages of the present invention will become more apparent from a detailed description of illustrative embodiments of the invention, taken in conjunction with the following figures, in which:

Fig. 1 shows an illustrative embodiment of an actuator according to the invention, in a first or "closed" position;

Fig. 2 shows the actuator of Fig. 1 in a second or "open" position;

Fig. 3 is a perspective view of a shield of the embodiment of Figs 1 and 2;

Fig. 4 shows an alternative embodiment of the invention utilizing three magnets in the actuator;

5 Fig. 5 shows the three magnet actuator of Fig. 4 with the shield in a first "closed" position ; and

Fig. 6 shows the three magnet actuator of Fig. 4 with the shield in a second "closed" position.

10

DETAILED DESCRIPTION OF THE INVENTION

The present invention is an actuator configuration that involves a plurality of magnetic fields working in conjunction to effect motion in a highly efficient manner.

15 Referring now to Figs. 1-3, a first illustrative embodiment of an actuator according to the invention comprises a first magnet 10 and a second magnet 12 disposed on a base 14. In this embodiment the first and second magnets are fixed to the base. The base 14 is disposed proximate to a linear bearing 16. The base 14 and linear bearing 16 are configured to move relative to each other in this embodiment. A shield 18 is
20 disposed in a manner to move relative to the first magnet 10 and the second magnet 12. The shield is driven to appropriate positions as described herein, by mechanical means (not shown), such as a linear actuator (solenoid, stepper motor, worm gear or the like), rotary actuator (cam, rotary bearing or the like) or any of various other actuators.

25

In Fig. 1 the actuator is in a first "closed" position., i.e. with the field of the second magnet 12 effectively blocked by the shielded magnet holding the shield 18 in place. Hence, when the magnetic shield is in the 'closed' position, the magnetic field from the actuating magnet (i.e. the second magnet 12) is effectively blocked by the

magnetic shield 18 (shown in detail in Fig. 3). There is little or no field just in front of the shield. Thus the second magnetic is effectively blocked and precluded from doing any work.

- 5 As illustrated in Fig. 2, when the actuator is in the 'open' position (i.e. the second magnet is not shielded) the magnetic field for the actuating magnet (i.e. the second magnet) operates as normal i.e., the magnetic field is not blocked. Hence this field is now 'active' in the position where it was previously blocked by the shield 18 (Fig. 3), and the first magnet is blocked.

10

In this manner the field from the second or actuating magnet (1) is effectively turned on and off. It should be appreciated that either of the first or second magnet can be used and designated as the "actuating" magnet.

- 15 As illustrated in Figure 1 and 2, the first magnet 10 acts as a "balancing magnet" and allows the movement of the shield 18 to happen for a relatively low amount of energy. Without this balancing magnet 10 the force to move the shield 18 down is relatively high and the system is highly inefficient. The balancing magnet 10 substantially reduces the energy required to move the shield 18 over the actuating
20 magnetic field.

The positioning of the magnetic shield 18 relative to the balancing and actuating magnets allows for minimal energy to effect actuation. In the open position (Fig. 2) the bottom edge of the magnetic shield should be close to the top edge of the
25 balancing magnet 10. In the closed position (Fig. 1) the top edge of the shield should be close to the bottom of the actuating magnet 12. Mechanical stops may be used to optimally position the shield or otherwise limit the movement thereof.

Fig. 1 shows a first illustrative embodiment of a magnetic actuator according to the

invention, comprising the first magnet 10 fixed to the base 14 which is made of aluminum. The second magnet 12 in this embodiment is of substantially equal strength as the first magnet 10 and is fixed to the base in relative position to the first magnet 10. In this embodiment the second magnet 12 is the actuating magnet in that when it is "open" (i.e. not shielded), it is used to perform work such as by interaction with other entities (for example, other proximate magnetic fields). The first magnet 10 is the balancing magnet in that its primary function is to interact with the shield 18 providing the blocking method for the magnetic fields.

10 The shield 18 in this embodiment is positioned in particular relation to both magnets, and is made of a magnetic shield material, such as NETIC S3.6 available from Magnetic Shield Corporation of Bensenville, Illinois. In this illustrative embodiment the bottom edge of the first magnet 10 is approximately 15mm from the top edge of the second magnet with the magnets being approximately 25 mm in diameter. In this 15 embodiment the shield is approximately 30 mm in width and 50 mm in height. In this embodiment the shield is configured such that an inner surface of the shield is approximately 5 mm from a top (flat) surface of the magnets). These dimensions are illustrative and are a function of the size of the actuator and shield.

20 It should be appreciated that more than a first and second magnet may be implemented in an actuator according to the invention. Fig. 4 shows an additional embodiment of the invention utilizing three magnets in the actuator. In this instance a third magnet 20 is substantially identical to the other two magnets in terms of size, strength and configuration. The third magnet 20 is disposed on the base 14 in such a 25 fashion that the shield can move in front of it on a linear bearing as per the previous embodiment.

Fig. 5 shows the three magnet configuration of Fig. 4 with the shield 18 now having reached the closed position in front of the second magnet 12. The movement of the

shield 18 along the linear bearing 16 from the third magnet 20 towards the second magnet 12 allows the magnetic field from the third magnet 20 (the actuating magnet) to operate as a function of its magnetic field being exposed.

5 Similarly, Fig. 6 shows the three magnet configuration of the actuator with the shield 18 having reached the closed position in front of the first magnet 10. The movement of the shield 18 along the linear bearing 16 from the second magnet 12 towards the first magnet 10 allows the magnetic field from the second magnet 12 (which now becomes the actuating magnet) to operate as a function of its magnetic field being
10 exposed. It should be appreciated that in the three magnet embodiment that two of the magnets may be used as actuating magnets.

The present invention is not restricted to the above embodiments. In relation to the magnets and shield, all magnets on the base are fixed to the base, such as by an
15 adhesive, and arranged such that their end portions are of the same polarity and the magnetic field radiates outward from the base. However, it is possible that the polarities of the outward end portions of the permanent magnets are alternately changed. The magnets may have different magnitudes of magnetic force. In addition the shield may be of varying dimensions and geometric configuration.

20 The system works by moving the magnetic shield in front of one of the permanent magnets or any of various other means of generating a magnetic field. Actuation of the shield in the foregoing embodiments is effected on a low friction linear bearing. The drive mechanism (not shown) for the shield is provided by an external force such as a solenoid, linear motor or the like. The addition of the balancing magnet allows
25 actuation operation to be done for relatively low amounts of energy. While a balancing magnet, or magnets are currently viewed to be the best method of achieving low energy actuation, it should be appreciated that various other methods can produce the same or similar results. Use of springs, pneumatics or the like can

also provide the balancing force. Furthermore, it should be appreciated that an actuator according to the invention can be implemented in a wide range of scales, from a miniature scale such as would be implemented in a micromechanical or micro electro mechanical structure to a large scale actuator such as implemented with large permanent magnets and other mechanical structures.

5

It should be appreciate that in the foregoing description that the use of the terms “open” and “closed” are nominal and are used for illustration purposes only, as are the terms “top” and “bottom.”

10

Although the invention is shown and described hereinbefore with respect to illustrative embodiments thereof, persons having ordinary skill in the art should appreciate that the foregoing and various other changes, omissions and additions in the form and detail thereof may be made without departing from the spirit and scope of the invention.

15

CLAIMS

What is claimed is:

1. A magnetic actuator, comprising:
a base;
5 a first magnet disposed on the base in a first position,
a second magnet disposed on the base in a second position relative to the first
magnet; and
a shield disposed proximate to the base and relative to the first magnet and
second magnet and configured for actuation between a first position and a second
10 position, when the shield is in the first position it substantially blocks a magnetic
field emanating from the first magnet and leaves a magnetic field emanating from the
second magnet substantially exposed, and when the shield is in the second position it
substantially blocks a magnetic field emanating from the second magnet and leaves a
magnetic field emanating from the first magnet substantially exposed.
15
2. The magnetic actuator of claim 1 characterized in that each of the first magnet
and second magnet is of similar field strength.
3. The magnetic actuator of claim 1 characterized in that the field that radiates
20 from the ends of the first magnet and the second magnets is of the same polarity.
4. The magnetic actuator of claim 1 characterized in that the shield is of a
thickness that effectively blocks the emitted magnetic field when positioned over one
of the first magnet and the second magnet.
25
5. The magnetic actuator of claim 1 further comprising a linear bearing and the
shield is disposed on the linear bearing and moves relative to the base.
6. The magnetic actuator of claim 1 wherein the first magnet is fixed to the base.

7. The magnetic actuator of claim 1 wherein the second magnet is fixed to the base.
- 5 8. The magnetic actuator of claim 1 further comprising a third magnet disposed on the base.

1/2

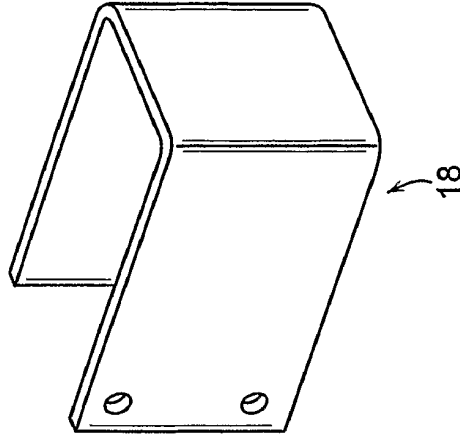

FIG. 3

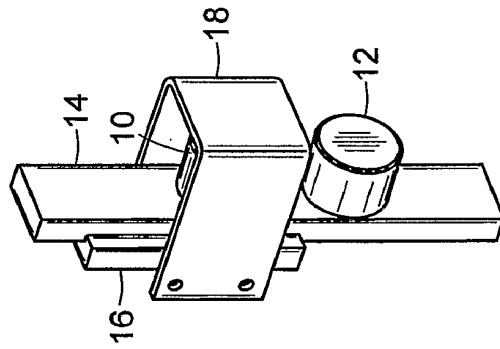

FIG. 2

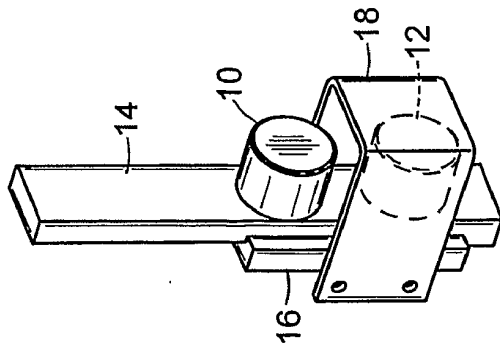

FIG. 1

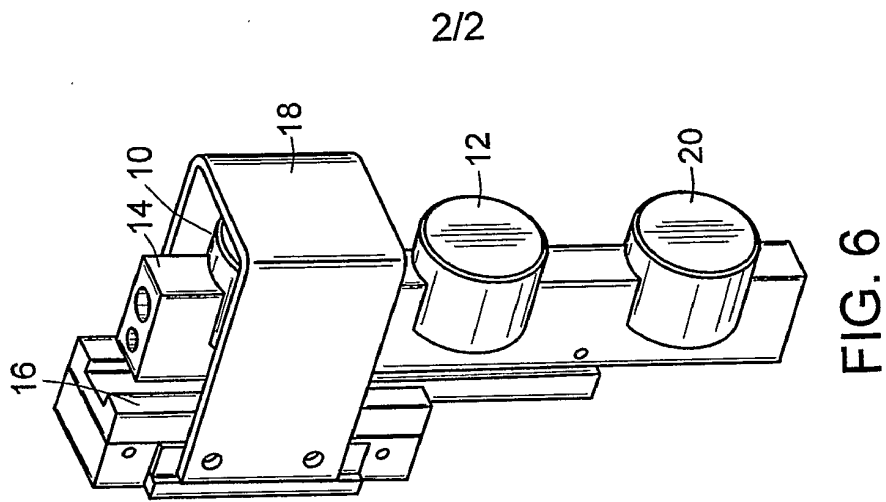

FIG. 6

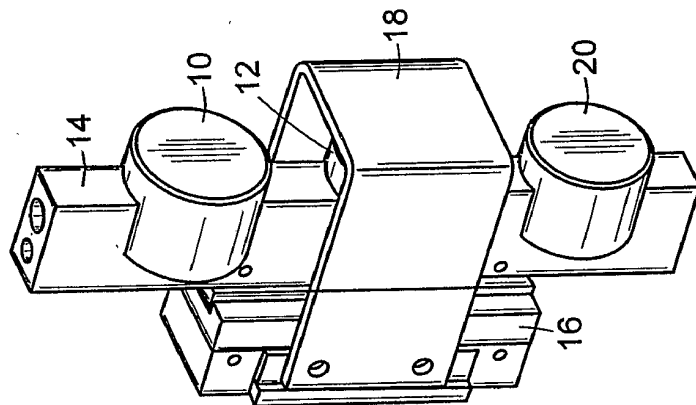

FIG. 5

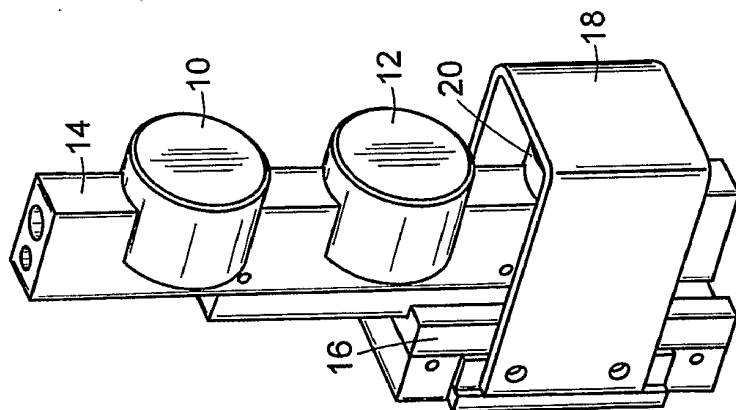

FIG. 4

INTERNATIONAL SEARCH REPORT

International Application No
PCT/IE2005/000107

A. CLASSIFICATION OF SUBJECT MATTER IPC 7 H01F7/02		
According to International Patent Classification (IPC) or to both national classification and IPC		
B. FIELDS SEARCHED		
Minimum documentation searched (classification system followed by classification symbols) IPC 7 H01F		
Documentation searched other than minimum documentation to the extent that such documents are included in the fields searched		
Electronic data base consulted during the international search (name of data base and, where practical, search terms used) EPO-Internal, WPI Data, PAJ		
C. DOCUMENTS CONSIDERED TO BE RELEVANT		
Category °	Citation of document, with indication, where appropriate, of the relevant passages	Relevant to claim No.
X	US 4 112 401 A (PALMER ET AL) 5 September 1978 (1978-09-05) column 8, line 22 - line 34; figure 8 -----	1-8
<input type="checkbox"/> Further documents are listed in the continuation of box C. <input checked="" type="checkbox"/> Patent family members are listed in annex.		
° Special categories of cited documents :		
A document defining the general state of the art which is not considered to be of particular relevance *E* earlier document but published on or after the international filing date *L* document which may throw doubts on priority claim(s) or which is cited to establish the publication date of another citation or other special reason (as specified) *O* document referring to an oral disclosure, use, exhibition or other means *P* document published prior to the international filing date but later than the priority date claimed		*T* later document published after the international filing date or priority date and not in conflict with the application but cited to understand the principle or theory underlying the invention *X* document of particular relevance; the claimed invention cannot be considered novel or cannot be considered to involve an inventive step when the document is taken alone *Y* document of particular relevance; the claimed invention cannot be considered to involve an inventive step when the document is combined with one or more other such documents, such combination being obvious to a person skilled in the art. *&* document member of the same patent family
Date of the actual completion of the international search 10 November 2005		Date of mailing of the international search report 18/11/2005
Name and mailing address of the ISA European Patent Office, P.B. 5818 Patentlaan 2 NL - 2280 HV Rijswijk Tel. (+31-70) 340-2040, Tx. 31 651 epo nl, Fax: (+31-70) 340-3016		Authorized officer Marti Almeda, R

INTERNATIONAL SEARCH REPORT

Information on patent family members

International Application No

PCT/IE2005/000107

Patent document cited in search report	Publication date	Patent family member(s)	Publication date
US 4112401	A	NONE	