

May 23, 1961

R. H. DU HAMEL

2,985,879

FREQUENCY INDEPENDENT ANTENNAS

Filed July 9, 1958

2 Sheets-Sheet 1

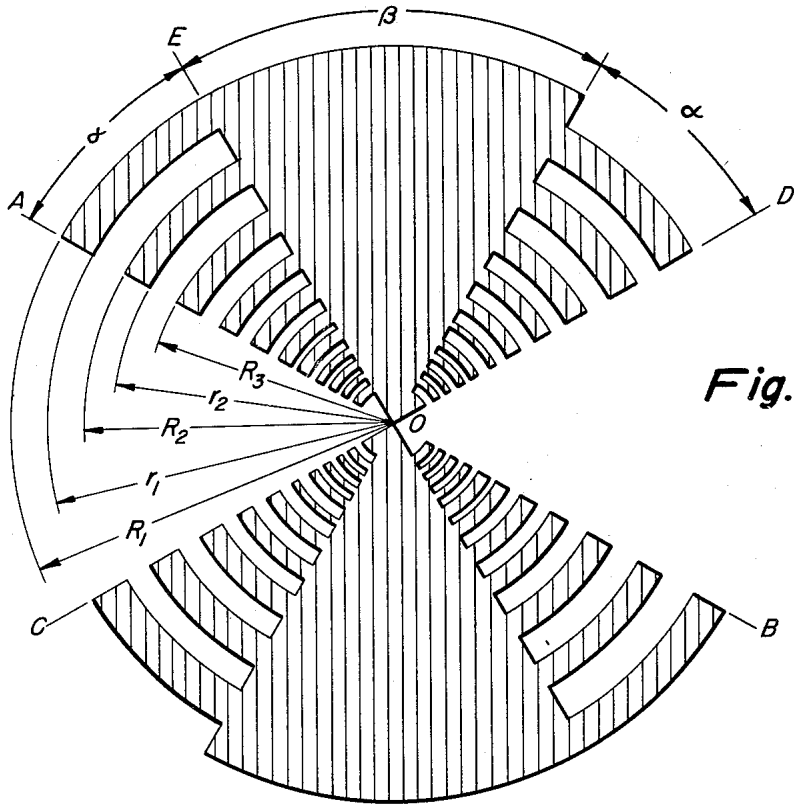
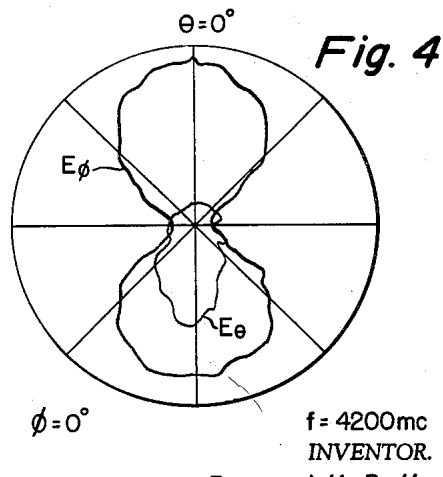
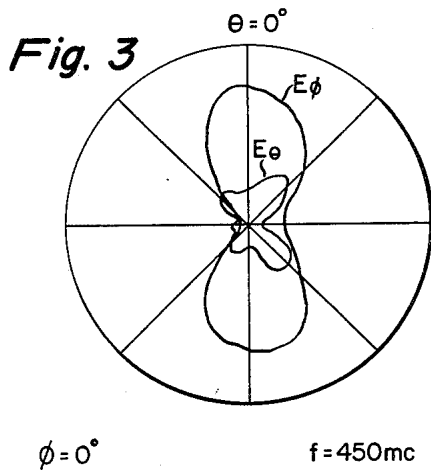

Fig. 1



INVENTOR.
Raymond H. Du Hamel

BY

Merriam, Lorch & Smith
ATTORNEYS

May 23, 1961

R. H. DU HAMEL

2,985,879

FREQUENCY INDEPENDENT ANTENNAS

Filed July 9, 1958

2 Sheets-Sheet 2

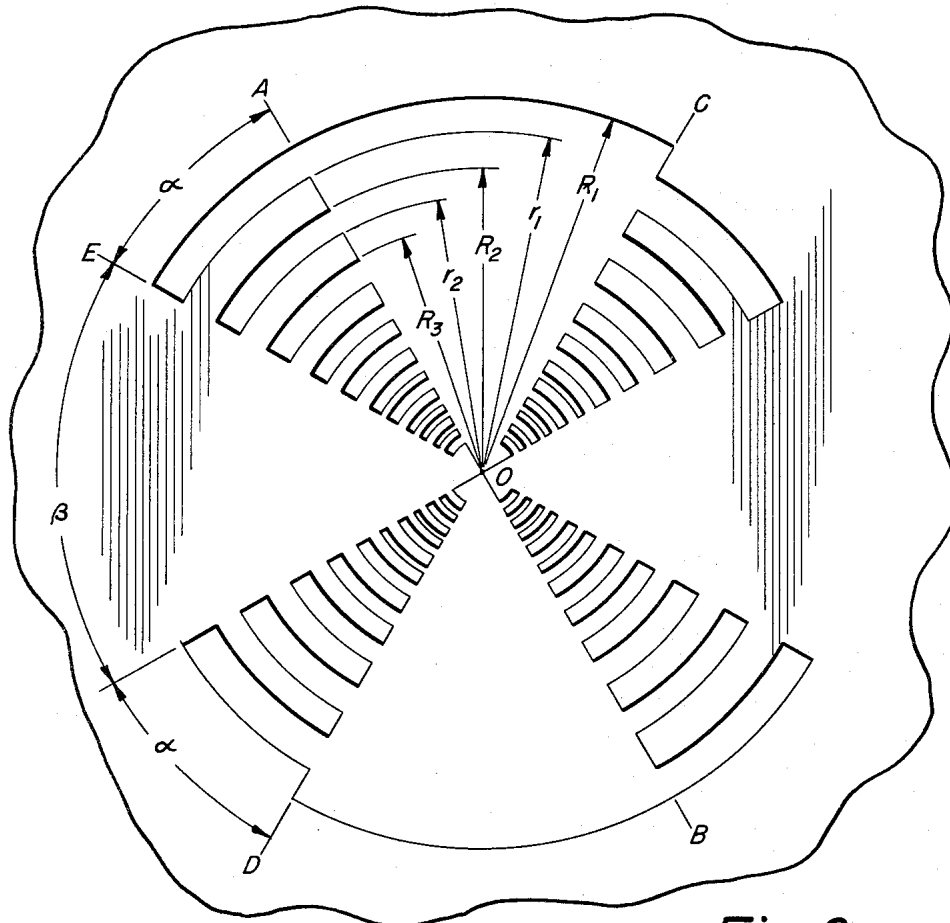

Fig. 2

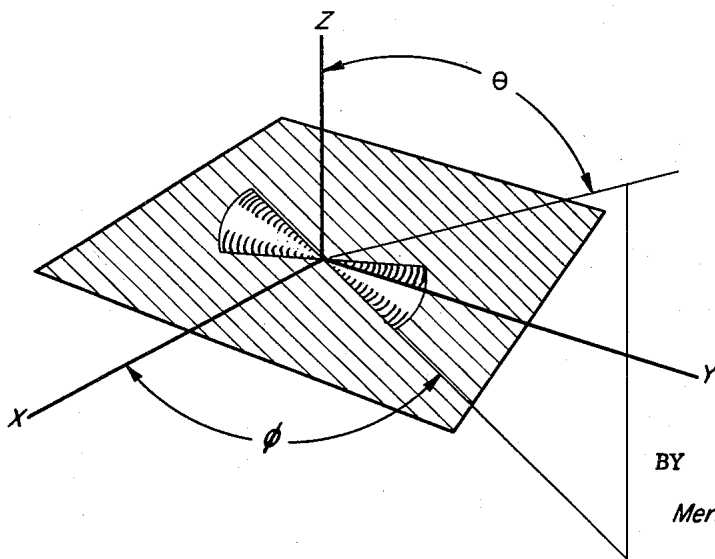

Fig. 5

INVENTOR.
Raymond H. DuHamel

BY

Merriam, Lorch & Smith
ATTORNEYS

1

2,985,879

FREQUENCY INDEPENDENT ANTENNAS

Raymond H. Du Hamel, Cedar Rapids, Iowa, assignor to The University of Illinois Foundation, Urbana, Ill., a corporation of Illinois

Filed July 9, 1958, Ser. No. 747,374

5 Claims. (Cl. 343—908)

This invention relates to antennas and more particularly it relates to antennas having radiation patterns and impedance characteristics that are essentially independent of frequency over wide band widths.

It is known that an antenna whose geometry is described completely by angles, such as an infinite biconical antenna, would make an ideal broadband radiator since its operation is theoretically completely independent of frequency. The theoretical performance of the infinite biconical antenna is not achieved in practice, however, since such an antenna must be of finite length, and the "end effect," i.e., the effect of finite rather than infinite length, leads to radiation characteristics showing considerable variation with frequency.

A planar antenna closely related to the biconical antenna (the "bow-tie" antenna) is likewise theoretically frequency-independent when infinite in size. The "end-effect" of an actual bow-tie antenna, however, limits the range of frequencies for which the radiation pattern is essentially constant to a bandwidth of 2 or 3 to 1.

The present invention concerns modified planar "bow-tie" antennas in which the "end-effect" has been reduced to such an extent as to permit bandwidths of 10 to 1 or more to be achieved with structures of practical size. In general, this effect is achieved by introducing periodic discontinuities along the marginal edges of the bow-tie antenna, the geometry of the discontinuities being such that all dimensions involved are directly proportional to the distance from the feed point of the antenna, i.e., the vertex or the narrowest portion of the "bow-tie."

The construction of the antennas of the present invention will be better understood from the following detailed description thereof, in which reference is made to the accompanying diagrams, wherein:

Figure 1 is a plan view of an antenna embodying the features of the invention.

Figure 2 is a slot antenna complementary to that shown in Figure 1.

Figures 3 and 4 are typical radiation patterns for the antenna of Figure 2.

Figure 5 is a sketch identifying the co-ordinate system used in Figures 3 and 4.

Referring to Figures 1 and 2, the antennas of the present invention comprise two identical substantially sector-shaped, electrically conducting elements partially defined by intersecting straight lines AB and CD, said sectors almost meeting (i.e., no electrical connection) at point O (the feed-point of the antenna), defined by the intersection of these lines. The marginal edges of each sector (e.g., AO and OD) contain a plurality of similar slots and teeth bounded by straight lines (e.g., EO and AO) and arcs of concentric circles having their common center at the feed-point (O) and having radii $R_1, R_2, \dots, R_n, R_{n+1}$, and $r_1, r_2, \dots, r_n, r_{n+1}$. The radii R_1, R_2, \dots and r_1, r_2, \dots form a geometric

2

series of terms wherein the geometric ratio of terms in the series is defined by

$$\tau = \frac{R_{n+1}}{R_n} = \frac{r_{n+1}}{r_n} = \text{a constant less than 1.}$$

The radii r_1, r_2, \dots bear a constant relationship to radii R_1, R_2, \dots which is defined by

$$\sigma = \frac{r_n}{R_n} = \text{a constant greater than } \tau \text{ and less than 1.}$$

The value of σ thus determines the width of the slots and teeth.

It can be seen that, because of the geometry of the antenna as defined above, the dimensions of any tooth (or slot) are directly proportional to its distance from the feed point.

Infinite antenna structures of the type of the invention have the property that, when energized at the vertex, the fields at a frequency f_1 will be repeated periodically at all other frequencies given by $\tau^n f_1$ where n may take on any integral value. The parameter τ determines what may be considered the bandwidth of a period of operation. That is,

$$\frac{f_2}{f_1} = \tau$$

where f_1 and f_2 are two frequencies exactly one period apart ($f_1 > f_2$). The shape of the antenna structures of the invention is such that the variation of the radiation pattern and impedance is small over one period, and because of the periodically repeating nature of the fields, the same will be true for all periods, the result being an extremely broadband antenna. For the finite structures of the invention it has been found that the fields along the antennas decay very rapidly after passing a point where a resonant discontinuity, such as a tooth one quarter wavelength long, exists. This decay of the field causes the "end effect" of the antennas of the invention to be small, so that wide bandwidths are readily obtained with structures of finite size.

It has been found that the lower and upper limits of the frequency band in which the radiation patterns are independent of frequency are determined by the longest and the shortest teeth, respectively, in the antenna. The low frequency limit is that for which the longest teeth are $\frac{1}{4}$ wavelength long. Likewise, the high frequency limit is that for which the shortest teeth are $\frac{1}{4}$ wavelength long. It can therefore be seen that the bandwidth of the antenna can be adjusted as desired by making the shortest and the longest teeth in the antenna correspond to $\frac{1}{4}$ wavelength of the desired frequency limits.

The antennas of Figures 1 and 2 are complementary to each other, i.e., Figure 2 is a slot antenna in which the cut-out portion is identical to the antenna of Figure 1. A complementary antenna is defined as the portion of the plane which is not covered by the original antenna: when an antenna and its complement are fitted together they cover the whole plane without overlapping. It is a property of planar antennas that any antenna having the same shape as its complement has a constant impedance which is independent of frequency. Thus in order that the antennas of the invention have impedances as well as patterns which are independent of frequency over the bandwidth, it is preferred that the equi-complementary condition exist, that is, an antenna should have the same shape as its complement. This can be accomplished in the antennas of Figures 1 and 2 by making the sum of angle α and angle β equal to 90° . Either of the equi-

complementary antennas (i.e., a given antenna or its equal complement) can be used with essentially identical results.

Although the particular embodiments of Figures 1 and 2 (i.e., in which the slots and teeth are defined by circular arcs) are preferred, the invention is not limited thereto. Other types of discontinuities can be used along the edges of the antenna, such as trapezoids, triangles, etc., provided that the dimensions of all such discontinuities are proportional to the distances from the feed point. Regardless of the actual configuration used for the discontinuities, it is preferred that all discontinuities in a given antenna have similar shapes.

It can be seen that the antennas of Figures 1 and 2 possess no axis of symmetry but are symmetrical about the feed point only. Symmetry about the feed point is defined as a configuration such that for every point in the antenna falling on a straight line passing through the feed point, there exists a corresponding point on the same line at an equal distance on the other side of the feed point. Although antennas made in accordance with the invention which possess one or more axes of symmetry exhibit some broadband characteristics, the bandwidths thereof are in general inferior to those of antennas which are symmetrical about the feed-point only, and which are therefore preferred.

In the preferred embodiment the same arcs which define the teeth and slots at one marginal edge of one of the elements of the antenna also define the teeth and slots on the other marginal edge of the same element. However, in order to avoid symmetry about an axis passing through the central imperforate conducting portion of the antenna, the slots and teeth on the edges are arranged such that each tooth has a corresponding slot and each slot has a corresponding tooth on the opposite edge of the element at the same distance from the feed point, the corresponding slot or tooth being a mirror image of the tooth or slot to which it corresponds.

In order to demonstrate the performance of the antennas of the invention, a number of antennas of the type shown in Figure 2 were constructed of light gauge copper sheet, approximately 0.020 inch thick. The periodic discontinuities were in the form of teeth defined by arcs of circles connected to a sector-shaped central conducting strip. In order to maintain an equi-complementary condition, the sum of angles α and β was made equal to 90° . A small area near the center of the antenna was left as solid conductor since continuation of the teeth in that direction requires an infinite number of teeth of zero width in the limit. For all models tested, the ratio σ , as defined above, was taken equal to the square root of the ratio τ , also defined above, providing a ratio of tooth to slot width which is the same for all rows of teeth. This however, is not a necessary condition since σ can assume any value greater than τ but less than 1.

Example 1

An antenna of the type of Figure 2 was constructed with the following values affixed to the variables:

$$\begin{aligned} R_1 &= 10 \text{ inches} \\ \tau &= 0.81 \\ \sigma &= \sqrt{\tau} = 0.9 \\ \alpha &= 45^\circ \\ \beta &= 45^\circ \end{aligned}$$

The antenna was fed across the vertex with a coaxial line having its outer conductor bonded to one half of the antenna and its inner conductor extended across the vertex and connected to the other half. The input impedance of this antenna measured over the band 400 to 1600 mc./sec. was found to be fairly constant with a mean value of approximately 150 ohms. Radiation patterns for the plane $\phi=0$ for this antenna are shown in Figures 3 and 4, which cover a bandwidth of almost 10 to 1 (from 450 mc. for Figure 3 to 4200 mc. for Figure 4). The coordinate system used for these radiation patterns is identified in Figure 5. It can be seen that these radiation patterns are

essentially uniform. The patterns for intermediate frequencies were found to be similar to those shown for the limits of the band.

Several additional models identical to that of Example 1 except for tooth angles were tested, having tooth angles ranging from $\alpha=20^\circ$ to $\alpha=60^\circ$, with τ held at 0.81, σ at 0.9 and R_1 at 10 inches. In each case the angle was adjusted so that the sum of α and β was 90° and the structure was thus maintained equal to its complement. The impedance of each of these antennas was found to be essentially equal to that for which $\alpha=\beta=45^\circ$, the only significant differences being the low frequency limits of constant input impedance. It was found that as the tooth angle α was decreased, holding R_1 fixed, the tooth lengths became shorter and the low frequency limit was raised. Thus, for the antenna in which $\alpha=20^\circ$, the low frequency limit for nearly constant input impedance is approximately 800 mc./sec. The radiation patterns for these antennas were found to be similar for all models, showing that the performance of the antenna is not peculiar to a particular tooth angle.

Additional antenna models similar to that of Example 1 were tested in which the parameter τ was varied over the range from 0.70 to 0.15. In each case the ratio σ was taken equal to $\sqrt{\tau}$, with $\alpha=\beta=45^\circ$ and R_1 maintained at 10 inches. The radiation patterns of these antennas were found to be independent of frequency above a certain low frequency, although the directivity was increased as τ was reduced, as shown in the following table, which gives average half-power beamwidths (that is, the average of both principal plane patterns for several frequencies over the band) for several values of τ .

TABLE I

τ	Average Half-Power Beamwidth, Degrees
0.81	73
0.70	70
0.50	55
0.25	38

It can be seen that the ratio τ provides a means for controlling the beamwidth of the antennas of this invention. It was found, however, that the low limit of frequency independent operation was increased as the directivity increased. Thus, in order to increase the directivity without affecting the bandwidth, it is necessary to increase angle α or R_1 (thereby increasing the length of the longest tooth) as well as decreasing the ratio.

Although the condition in which an antenna is equal to its complement is preferred, it is not necessary for achieving wide bandwidths for which the radiation patterns are independent of frequency. This was demonstrated by the construction and testing of an antenna similar to that of Example 1, except for angles α and β which were given the values 45° and 75° respectively. This antenna exhibited no degradation of the radiation patterns, compared to the antenna of Example 1. The input impedance of the antenna, however, had been reduced to a mean value of about 100 ohms and exhibited considerable variation with frequency. In order therefore to secure the best impedance match between the antenna and the transmission line feeding the same for all frequencies in the band, it is preferred to construct the antenna such that it is equal to its complement.

The two halves of the antennas of the invention are fed at the vertices thereof either with a balanced two wire line or with a coaxial line having the outer conductor bonded to the vertex of one half of the antenna and the inner conductor attached to the vertex of the other half. In either case there should be no electrical connection between the halves of the antenna (other than through the transmission line) in order to avoid a short-circuit.

5

The foregoing detailed description has been given for clearness of understanding only, and no unnecessary limitations should be understood therefrom, as modifications will be obvious to those skilled in the art.

I claim:

1. An antenna formed of an electrically conducting material having an outline partially defined by a pair of intersecting straight lines, the point of intersection of said lines being the feed point of said antenna, the marginal edges of said antenna containing a plurality of alternating slots and teeth, the dimensions of each of said slots and teeth being proportional to its distance from said feed point.

2. A planar antenna formed of an electrically conducting material, said antenna having an outline partially defined by a pair of intersecting straight lines forming two opposed substantially V-shaped elements, the point of intersection of said straight lines being the feed point of said antenna, each of said elements comprising an imperforate central sector-shaped portion and slotted sector-shaped portions of equal angular width on either side of said central portion, said slotted portions containing a plurality of alternating parallel slots and teeth, the dimensions of each of said slots and teeth being proportional to its distance from the feed point.

3. The antenna of claim 2 wherein the sum of the angles subtended at the feed point by one of said slotted portions and one of said central portions equals 90° .

6

4. The antenna of claim 2 wherein said slots and teeth are defined by straight lines passing through said feed point and arcs of concentric circles having their centers at the feed point.

5. The antenna of claim 2 wherein said elements have identical configurations, said antenna being symmetrical about the feed point, the teeth and slots in each element being arranged such that each tooth has a corresponding slot and each slot has a corresponding tooth, said corresponding slots and teeth being mirror images of the teeth and slots located on the opposite marginal edge of said element at equal distances from the feed point.

References Cited in the file of this patent

UNITED STATES PATENTS

2,192,532	Katzin	Mar. 5, 1940
2,480,154	Masters	Aug. 30, 1949
2,638,545	De Peau et al.	May 12, 1953

OTHER REFERENCES

Du Hamel and Isbell: "Broadband Logarithmically Periodic Antenna Structures," March 1957, I.R.E. National Convention Record, Part I, pp. 119-128.

Kraus: Antennas, McGraw-Hill, New York, 1950 pp. 367-371.