

[A Practical Guide to 'Free Energy' Devices](#)

Part D16: Last updated: 7th October 2006

Author: Patrick J. Kelly

The Water-Splitter of Frank Roberts

The material presented here is for information purposes only. Experimenting with hydrogen and/or a mixture of hydrogen and oxygen is highly dangerous and you do so entirely at your own risk. Neither Frank Roberts nor any other person connected with the preparation or display of this material recommends that you to do so and they disclaim any responsibility should you decide to do so against their advice.

Frank Roberts holds degrees in both Electrical Engineering and in Physics and has been in Research and Development for thirty years and he has been awarded seventeen patents in various areas. He has taught computer design and software engineering at university level and has written one textbook. At the present time, Frank is in poor health, suffering from intermittent short-term and long-term amnesia. The following description of his electrolyser system has been deduced from his postings to an enthusiast discussion group. It should be stressed that I personally have never seen this particular device in action, nor do I know anybody who has. Having said that, almost every feature of his system has been incorporated in various other different designs which have worked well.

A major advantage of this system is that it uses ordinary tap water. This type of system has been proven by Dave Lawton as described in the "D14.pdf" document. Another advantage is that the water in the cell covers the electrode plates, which allows easy topping up of the water and a considerable volume of water to be used before topping up is necessary. A third advantage is that it uses a (nominal) 12 volts electrical supply without the need for a transformer or inverter.

It should perhaps, be remarked that strictly speaking, this device is a water-splitter rather than an electrolyser and consequently, the voltage and gas rate limits determined by Faraday do not apply to it. The unit is driven by a DC pulsing circuit, details of which are provided in this document. Frank specifies square wave pulsing at 45 KHz with a 90% On and 10% Off, Mark/Space ratio, for his unit. While the circuit shown in this document can produce that, it can also vary the Mark/Space ratio over the full range, vary the frequency over a wide range and can optionally, gate the output signal to produce recurring bursts of pulses of the type shown by Stan Meyer in his patents.

The cell contains 60 electrode plates 6 inches (150 mm) square, made from 316L-grade stainless steel. These plates are grouped in three sets of 20 plates. The gap between adjacent plates in each group is 0.039 inches (1 mm) and the applied voltage is a nominal 12 volts, which means that when mounted in a vehicle, the actual voltage will be some 13.8 volts when the engine is running. The wiring arrangement for the plates has three identical sets of plates wired in series. While it would not be possible to have a series cell in a single body of electrolyte, the use of plain water with its high resistance to current flow, combined with the very close plate separation and the large gap between the sets of plates, does allow a series cell to be constructed this way. The thickness of the stainless steel plates is not important, so long as they are thick enough to be sufficiently rigid to stay in position during use - Frank used 22 gauge steel (0.031 inches or 0.8 mm thick). The container is made from acrylic sheet. This is sometimes sold under the trade names of "Plexiglas" or "Lexan". An alternative type of plastic is "Vivak". Frank opted for 1/4 inch (6 mm) thick sheet with aluminium angle at the corners, and the bolt heads bedded in silicon compound inside the case.

It should be noted that shiny new stainless steel is **not** suitable for use as an electrode in any form of electrolysis. When the power is first applied, very little electrolysis takes place in the tap water, as the active surfaces of the plates get covered with bubbles which stick to them. Frank prepared his plates for use by cleaning them with sandpaper and then soaking them in acetone for two or three days. At this point, the plates are said to be 'conditioned' and they produce much more rapid electrolysis than unconditioned plates can.

The electrical connections to the plates are made with bolts and washers. The output from the cell goes through a bubbler and then to commercial fuel injectors. The pressure inside the cell is maintained in the 40 to 45 pounds per square inch range as the fuel injectors require 40 psi. If injectors are not being used, then the pressure can be very much lower.

Frank adapted his 3-litre, 1994 Ford Taurus for long-term use by replacing the valves, sparkplugs and exhaust system with stainless steel versions. The fuel injectors are like standard fuel injectors except the injection opening is larger and they are provided with a special coating as, unlike a standard injector, they do not get any fossil fuel lubrication. Frank suggests http://www.qtw.com/products/hydrogen_alt_fuel/injectors/index.php as a source for hydrogen fuel injectors. He states that he has driven his Taurus at speeds of up to 85 mph for sustained periods and even at that speed, there was no lack of hydroxy gas from his cell to power the engine. As a rough guide, Frank says that the unit can convert water to gas at a rate of three US gallons per hour (about 305 litres of gas per minute). Replacement water is pumped into the cell using a standard vehicle electric fuel pump:

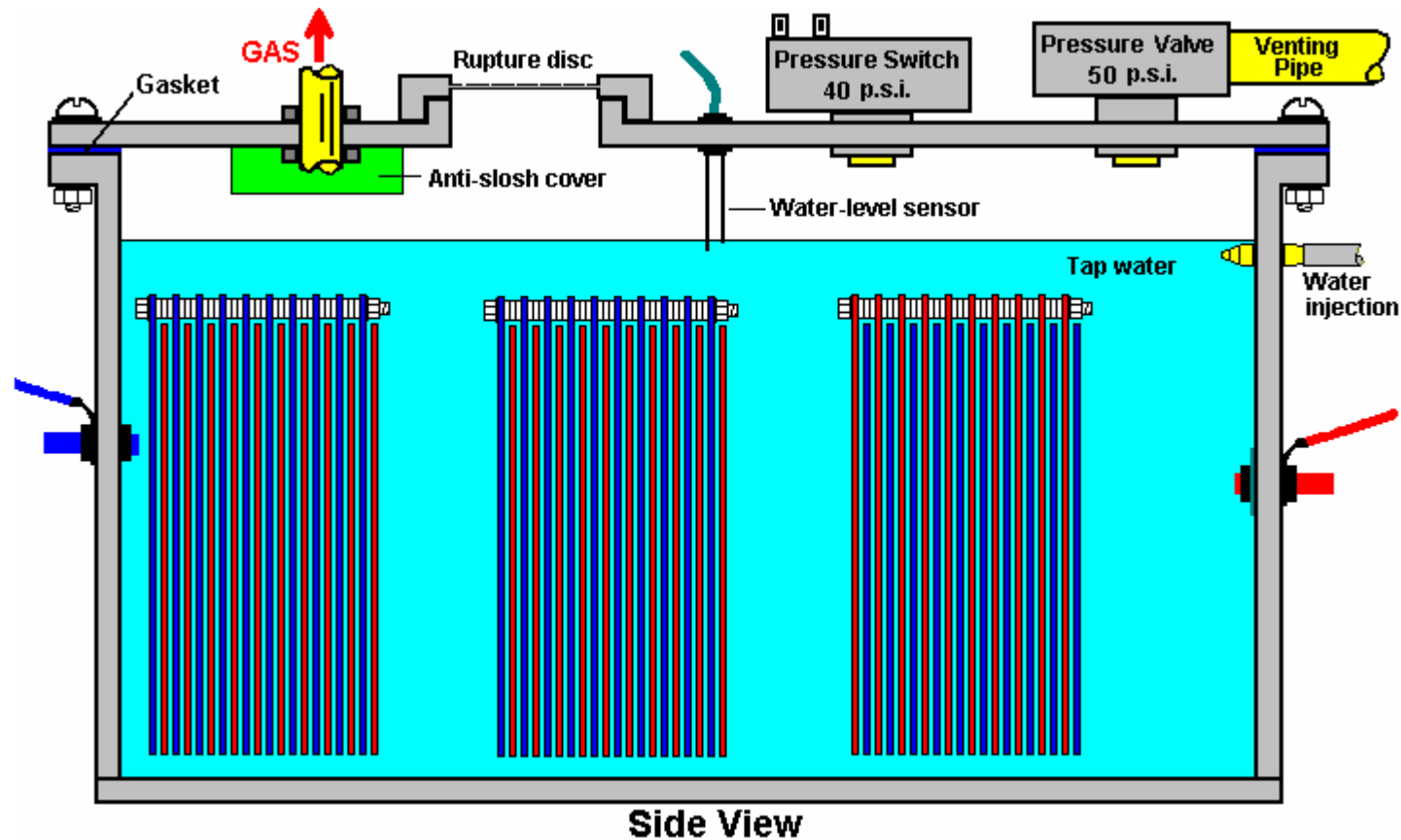

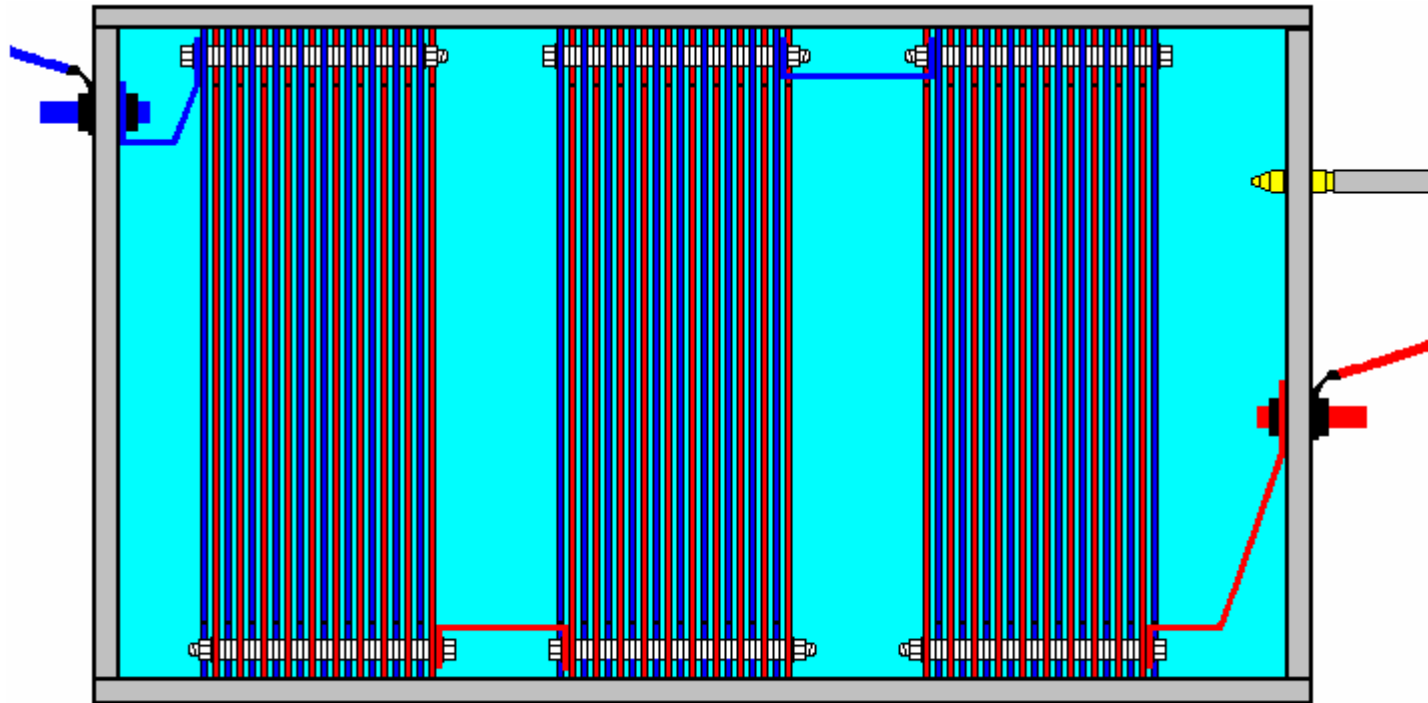

Top View

Frank describes this water-splitter unit as using 0.7 litres of water per hour at 65 mph. while the Taurus used to give about 20 mpg on gasoline. It should be noted that for clarity, the above diagrams show three sets of 16 plates rather than the three sets of 20 plates of the actual design. So, in the working unit, each group of plates has 19 gas-producing slots, giving a total of 57 slots. There will be no appreciable gas production across the one-inch gap between the sets of plates, due to the large separation of the plates, the gas production rate in a water-splitter being proportional to the spacing of the electrodes - the smaller the gap, the greater the rate of production. That is why the plates in this cell have only a 1 mm gap between them, as that is considered to be the minimum separation which will not block the gas bubbles. It should be noted that there is a quarter inch (6 mm) gap below the plates. This lets water be drawn up between the plates by the bubbles rising. The water sensor is placed in the middle of the unit so that it is not affected by the vehicle going up a hill.

A pressure-activated stainless steel electrical switch is used to disconnect the electrical supply from the cell and prevent excessive pressure. It switches on at 40 psi and switches off at 45 psi. If, during normal operation, a pressure of 50 psi is reached, then an emergency situation has occurred. To deal with this, two safety devices are included. The first is a stainless

steel mechanical pressure-release valve which operates at 50 psi. If this is activated, it vents the gas safely outside the vehicle through a tube which prevents any gas being trapped inside the engine compartment. The second safety device is a rupture disc which breaks in 2 milliseconds and produces no dangerous fragments. It is made from a thin sheet of metal, scored in such a fashion as to make it break up at a pressure of 60 psi. In the most unlikely event of an accidental explosion in the cell the rupture disc would vent the explosion harmlessly.

Frank's advice is to use the coldest sparkplug you can find. This carries away the heat from the sparkplug tip into the engine block avoiding pre-ignition. Never, use a platinum-tip sparkplug as the platinum acts as a catalyst causing the hydrogen to combine with the oxygen on contact with the platinum. Frank also says that it is important that good crankcase ventilation is maintained as some hydroxy gas will get past the rings if it builds up in the crankcase it can ignite and cause an unpleasant experience. The fuel injection is between two and fifteen degrees after Top Dead Centre on the intake stroke. Frank has used mixes as lean as 34:1 but he recommends a 20:1 air/gas ratio for additional power with his 3-litre engine. The spark is retarded to 2 to 15 degrees after Top Dead Centre. Frank converted his vehicle to hydroxy use in Autumn 2002 and has run it for about 1,200 miles since then with trips of about 50 miles at a time. He uses tap water drawn from the hot tap as some of the added gasses are driven off by the heating system. It should be noted that with all the steel and water in it, the cell is a heavy unit and needs a robust mounting bracket to hold it securely during the vibration and impacts of motoring use. This is the circuit of a suggested voltage pulser unit:

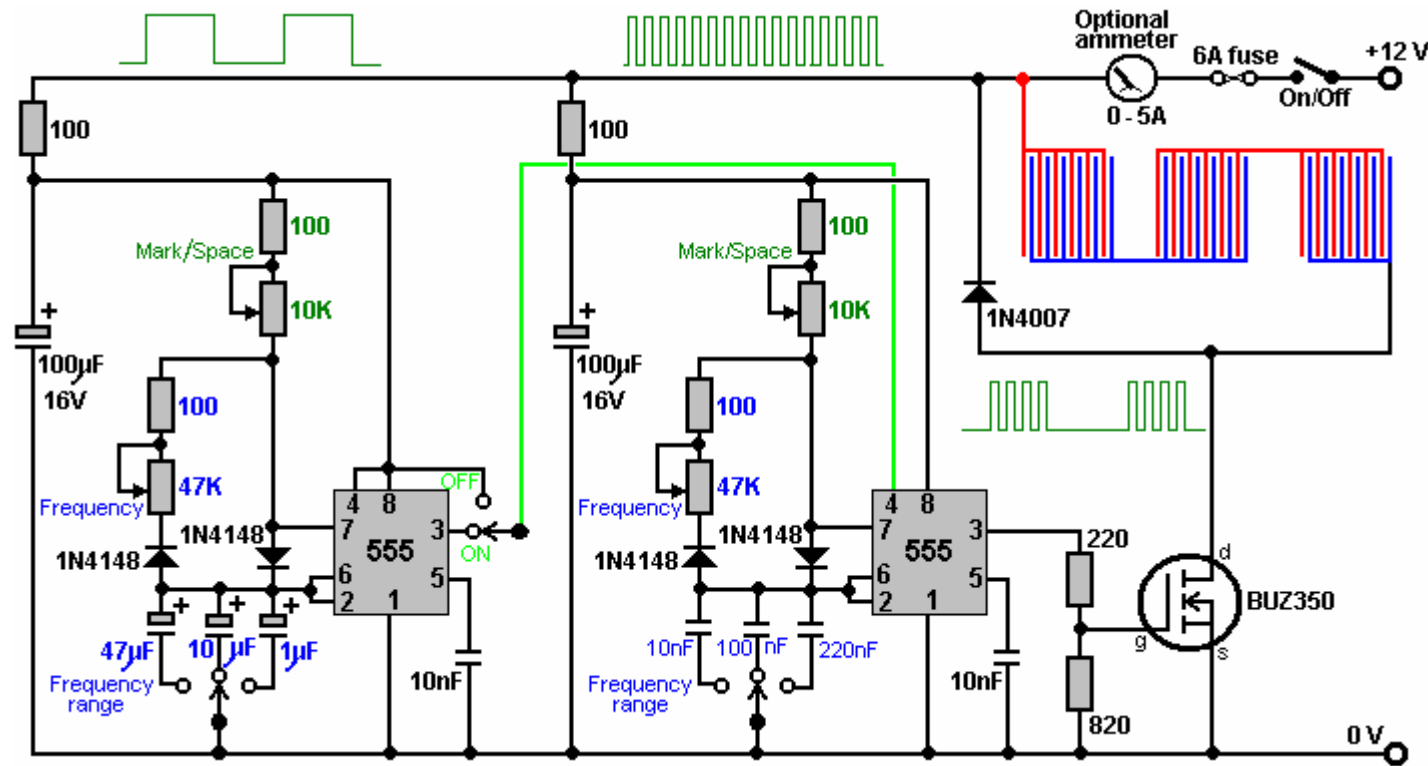

Circuit operation:

Each NE555 timer chip is placed in an oscillator circuit which has both variable pulse rate (“frequency”) and variable Mark/Space ratio which does not affect the frequency. These oscillator circuits also have three frequency ranges which can be selected by a rotary switch. The variable resistors each have a 100 ohm resistor in series with them so that their combined resistance cannot fall below 100 ohms. Each oscillator circuit has its supply de-coupled by placing a 100 microfarad capacitor across the supply rails and feeding the capacitor through a 100 ohm resistor. This has the effect of reducing any pulsing being carried along the battery connections to affect the adjoining circuit.

The first NE555 circuit has fairly large capacitors which give it comparatively slow pulses, as represented by the waveform shown above it. The output from that NE555 is on pin 3 and can be switched to feed the waveform to pin 4 of the second NE555 timer. This gates the second, higher frequency oscillator On and Off to produce the output waveform shown just below the pipe electrodes. The switch at pin 3 of the first NE555 allows the gating to be switched off, which causes the output waveform to be just a straight square wave of variable frequency and Mark/Space ratio.

The output voltage from pin 3 of the second NE555 chip is reduced by the 220 ohm / 820 ohm resistor combination. The transistor acts as a current amplifier, capable of providing several amps to the electrodes. The 1N4007 diode is included to protect the MOSFET should it be decided at a later date to introduce either a coil (“inductor”) or a transformer in the output coming from the MOSFET, as sudden switching off of a current through either of these could briefly pull the ‘drain’ connection a long way below the 0 Volt line and damage the MOSFET, but the 1N4007 diode switches on and prevents this from happening by clamping the drain voltage to -0.7 volts if the drain is driven to a negative voltage.

The BUZ350 MOSFET has a current rating of 22 amps so it will run cool in this application. However, it is worth mounting it on an aluminium plate which will act both as the mounting and a heat sink. The current draw in this arrangement is particularly interesting. With just one tube in place, the current draw is about one amp. When a second tube is added, the current increases by less than half an amp. When the third is added, the total current is under two amps. The fourth and fifth tubes add about 100 milliamps each and the sixth tube causes almost no increase in current at all. This suggests that the efficiency could be raised further by adding a large number of additional tubes, and as the gas is produced inside the tubes and the outer tubes are connected electrically, they could probably be bundled together.

Although the current is not particularly high, a six amp circuit-breaker, or fuse, should be placed between the power supply and the circuit, to protect against accidental short-circuits. It is **vital** that at least one bubbler is placed between the water-splitter and the engine, to give some protection if the gas should get ignited by an engine malfunction. It is also a good idea for the bubbler lid to be a tight push-fit so that it can pop off in the event of an explosion, and so further limit the effect of an accident.

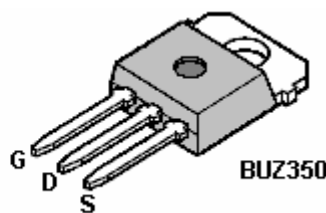
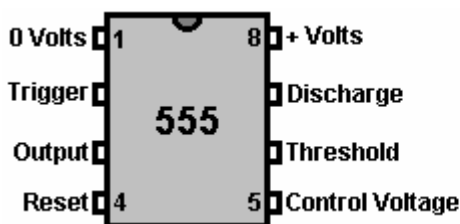

A possible component layout is shown here:

• = Track cut on underside of the board

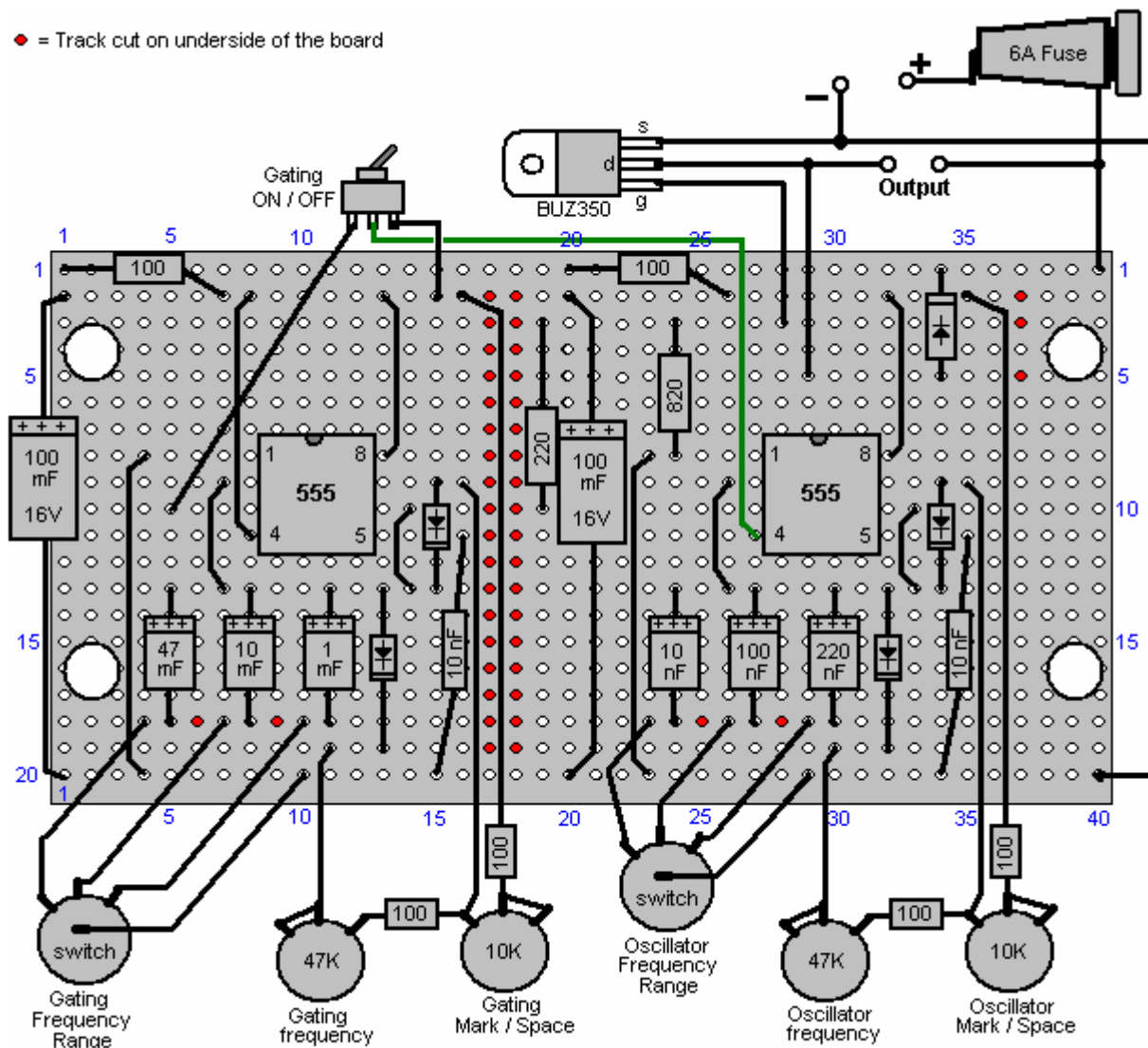

The underside of the stripboard is shown here:

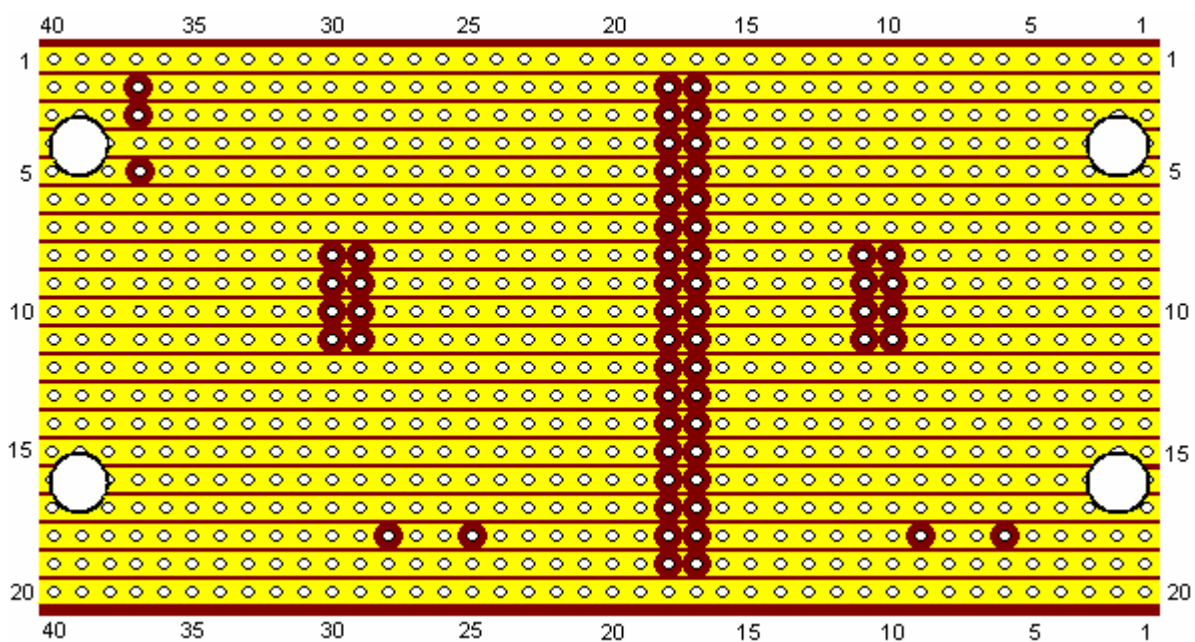

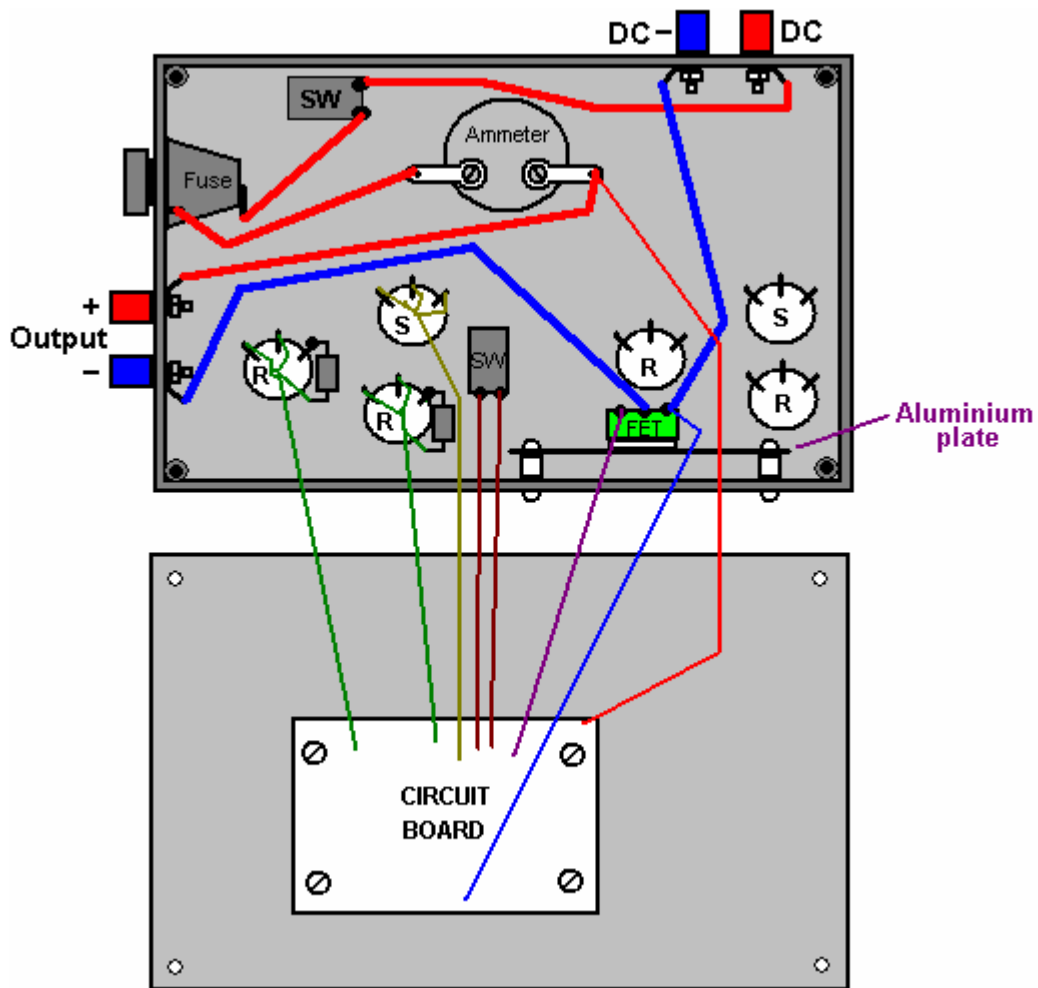

Component	Quantity	Description	Comment
100 ohm resistors 0.25 watt	6	Bands: Brown, Black, Brown	
220 ohm resistor 0.25 watt	1	Bands: Red, Red, Brown	
820 ohm resistor 0.25 watt	1	Bands: Gray, Red, Brown	
100 mF 16V capacitor	2	Electrolytic	
47mF 16V capacitor	1	Electrolytic	
10 mF 16V capacitor	1	Electrolytic	
1 mF 16 V capacitor	1	Electrolytic	
220 nF capacitor (0.22 mF)	1	Ceramic or polyester	
100 nF capacitor (0.1 mF)	1	Ceramic or polyester	
10 nF capacitor (0.01 mF)	3	Ceramic or polyester	
1N4148 diodes	4		
1N4007 diode	1		FET protection
NE555 timer chip	2		
BUZ350 MOSFET	1	Or any 200V 20A n-channel MOSFET	
47K variable resistors	2	Standard carbon track	Could be screw track
10K variable resistors	2	Standard carbon track	Could be screw track
4-pole, 3-way switches	2	Wafer type	Frequency range
1-pole changeover switch	1	Toggle type, possibly sub-miniature	Any style will do
1-pole 1-throw switch	1	Toggle type rated at 10 amps	Overall ON / OFF switch
Fuse holder	1	Enclosed type or a 6A circuit breaker	Short-circuit protection
Veroboard	1	20 strips, 40 holes, 0.1 inch matrix	Parallel copper strips
8-pin DIL IC sockets	2	Black plastic, high or low profile	Protects the 555 ICs
Wire terminals	4	Ideally two red and two black	Power lead connectors
Plastic box	1	Injection moulded with screw-down lid	
Mounting nuts, bolts and pillars	8	Hardware for 8 insulated pillar mounts	For board and heatsink
Aluminium sheet	1	About 4 inch x 2 inch	MOSFET heatsink
Rubber or plastic feet	4	Any small adhesive feet	Underside of case
Knobs for variable resistors etc.	6	1/4 inch shaft, large diameter	Marked skirt variety
Ammeter	1	Optional item, 0 to 5A or similar	
Sundry connecting wire	4 m	Various sizes	

Cell Assembly Suggestions

This is one of the easiest cell construction methods. The plates are all the same size (6 inch or 150 mm being the suggested size) and square in shape. The method of construction is not critical. The plates should be tested with a magnet to confirm that they are genuinely Grade 316L steel as some supplies are not what they claim to be. A magnet should fall off the steel, being unable to sustain it's own weight due to the lack of magnetic capability of the stainless steel.

The plates are cleaned carefully and then scored in a criss-cross hatching pattern using coarse sandpaper. Care must be taken not to touch the sanded plates with bare skin as that leaves a film of grease on the surface of the plates. Instead, the plates are held by the edges so that the flat surface is not touched (rubber gloves can be worn). The plates are then immersed in acetone. Please be aware that acetone is a hazardous liquid and great care must be taken when using it, to avoid all contact with the liquid or its fumes. Working outdoors in dry weather would be a sensible precaution.

One option for making sure that adjoining plates do not touch each other, is to drill each plate with an additional hole (or holes) and when the plates are being bolted together, and additional plastic bolt and plastic washers can be used to clamp the plates securely in position.

As the weight of water and steel inside the cell is considerable, Frank uses a style of construction which reinforces the joins in the plastic sheet with aluminium angle strip and stainless steel bolts as shown here:



Frank opted for cutting a triangle off the top corner of each electrode plate and drilling a hole in the opposite top corner. Every second plate is turned around so that the hole in it is positioned in the space left by the triangle removed from the plates on each side of it. So the electrical connections as shown here:

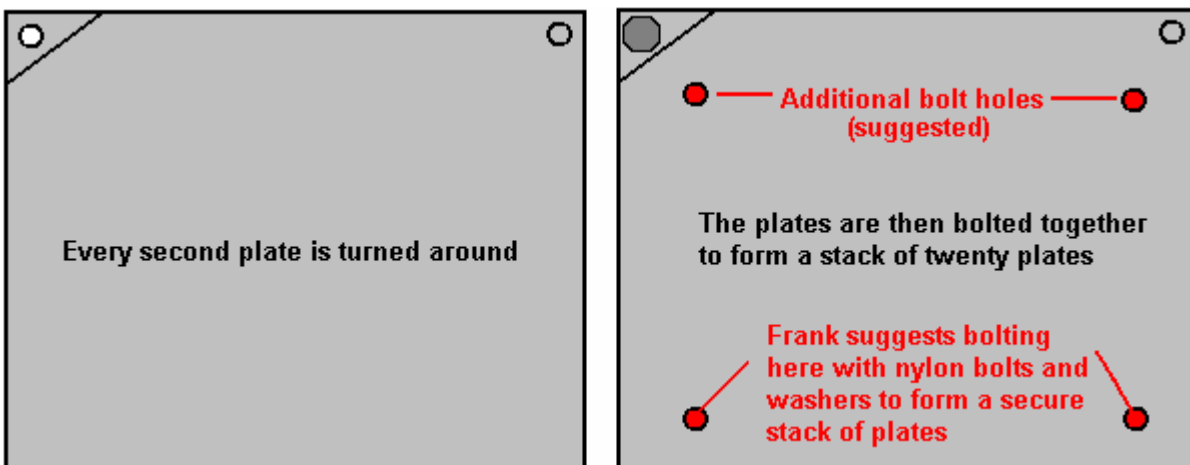
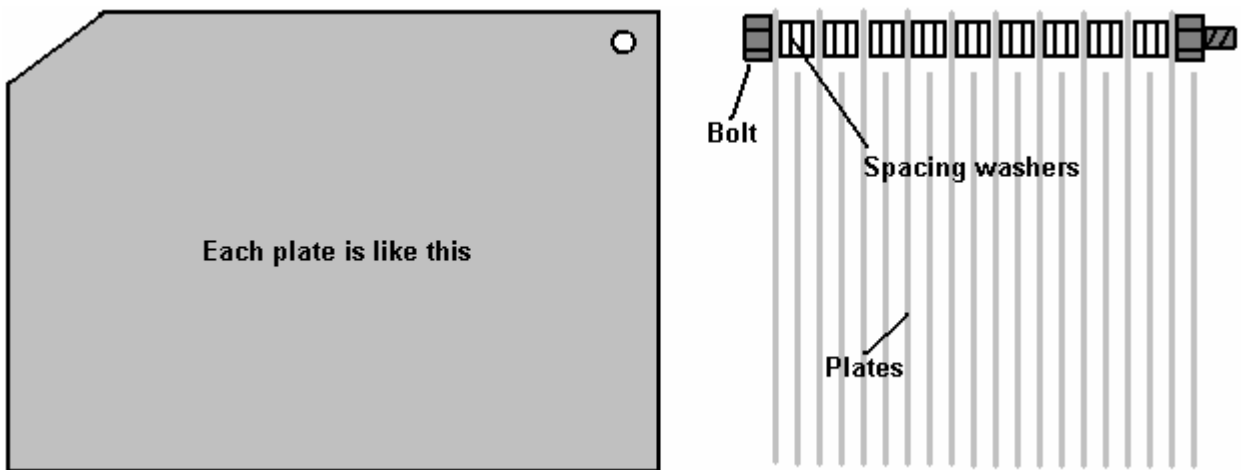

This style of construction makes it very easy to take the plates apart for inspection and cleaning, should that be considered to be desirable. The additional holes for the plastic bolts and plastic spacing washers have not been shown, but ideally, there should be at least two of these to provide a minimum of three mounting points per plate.



You will notice that the sets of plates are positioned inside the housing so that they avoid the heads of the bolts used to clamp the aluminium angle strips used to reinforce the cell. In the construction shown here, the sets of plates are not exactly centred inside the housing. This does not matter at all as there is adequate clearance between the sets and, of course, the internal volume is not altered in any way.

You will also note that underneath the plates there are two strips of plastic used to support the plates and keep the lower edges of the plates off the base of the cell. This gap allows water to flow up between the plates when the cell is operating, to replace the water displaced by the upward movement of thousands of tiny gas bubbles rising to the surface.

The electrical connections to the sets of plates are made with stainless steel straps as these act as mounting brackets to hold the plates in position as well as carrying the electrical current to the plates. The electrical current is low as this is a water-splitter and not a standard DC electrolyser which relies on high current to generate a large volume of gas.

The anti-slosh material, used to prevent water splashing up into the gas outlet tube, can be the plastic matting used with aquariums. Plastic pot scrubbers have also been suggested as a good material for use in this position.

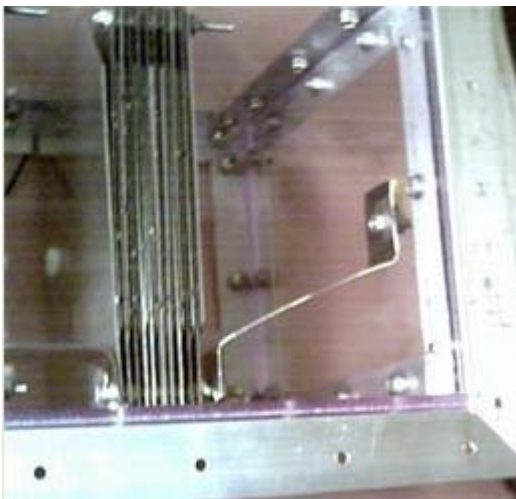
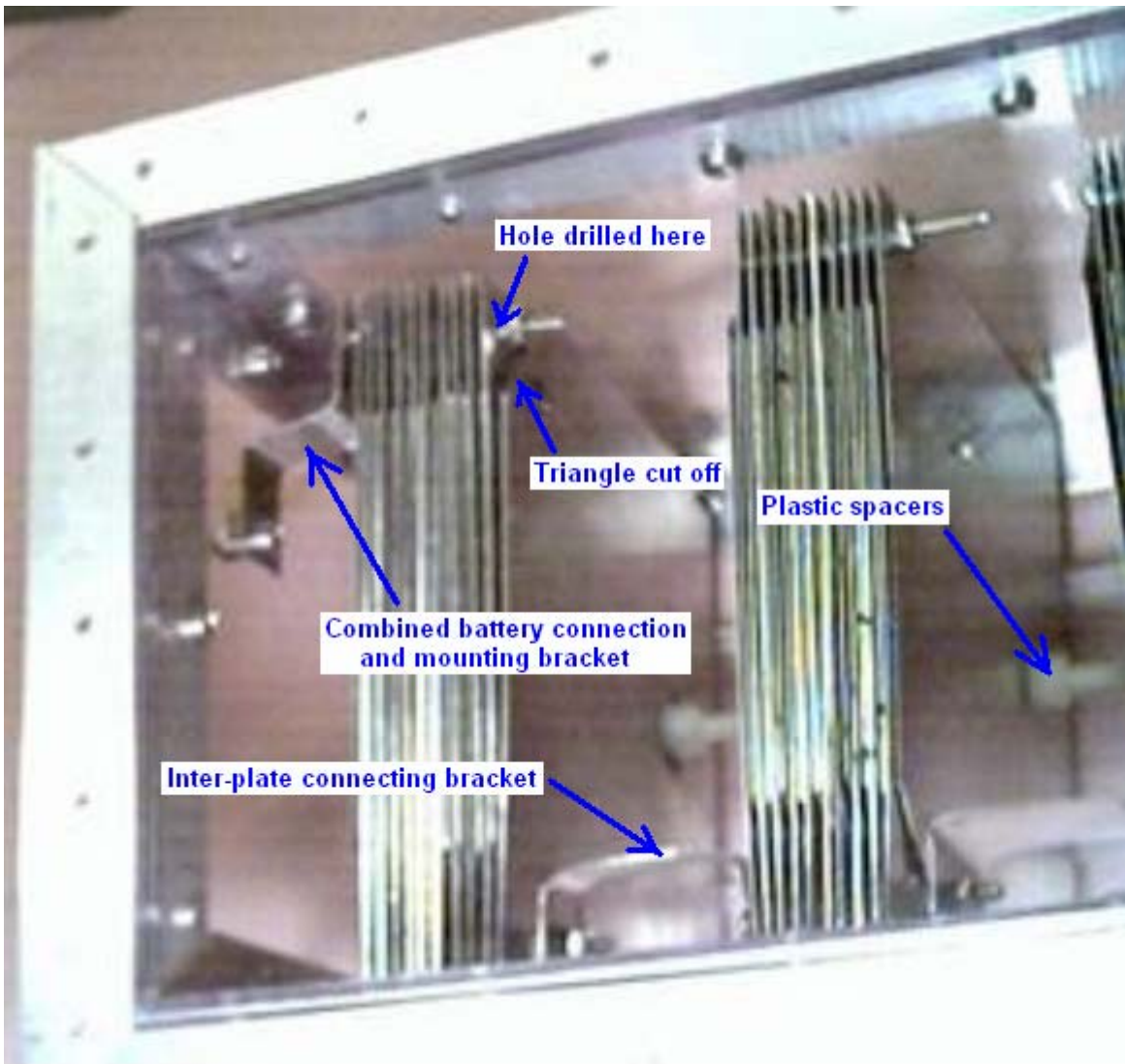

And positioned in the engine compartment:



As mentioned earlier, it is absolutely vital that every precaution be taken to avoid an explosion. The “hydroxy” gas produced by this cell is mainly hydrogen gas and oxygen gas which are already mixed together in the ideal proportions for them to recombine to form water again. That happens when the gasses are lit, and as the flame front of the ignition is about 1,000 times faster than the flame front when petroleum vapour is ignited, standard flash-back protection devices just do not work. The best protection device is a ‘bubbler’ which is a simple container which feeds the gas up through a column of water as shown here:

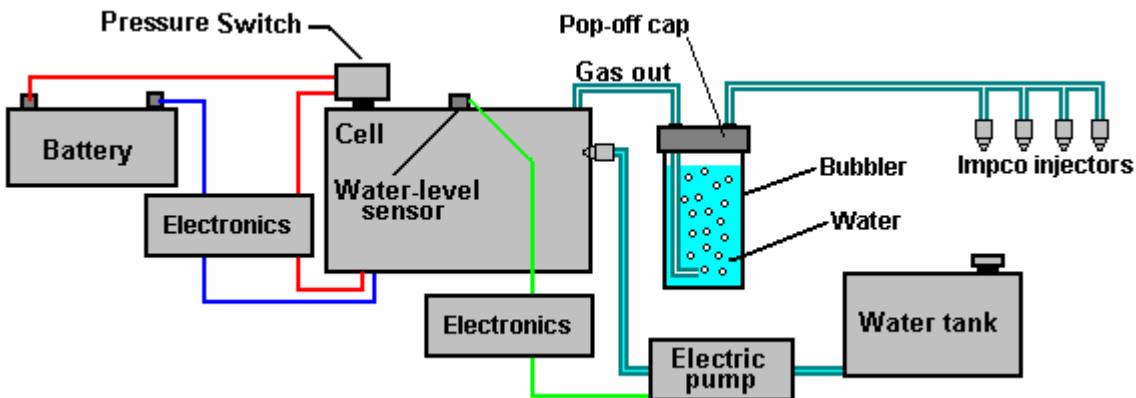

Ideally, a bubbler should have a tightly-fitting pop-off lid so that should the gas inside it be ignited, then the lid will be blown off instantly, robbing the explosion of its power. Some people like to place a one-way valve in the gas pipe between the cell and the bubbler to ensure that no sudden pressure is passed back to the cell.

If it is intended to use the electrolyser to feed an internal combustion engine, then the timing of the spark will need to be adjusted, and if the engine is very small and has a waste spark, then that needs to be dealt with as well. These details are covered in the “D9.pdf” document which forms part of this set of documents.

The circuit used for the water-level sensor is not in any way critical. Any circuit which switches the pump on when water does not bridge the sensor, and switches the pump off when the water reaches the sensor again will be suitable for this task.

The following simple circuit might be used for this. Tutorials in basic electronics and circuit board construction, which show how this circuit can be constructed quite easily, can be found on the web site mentioned below.

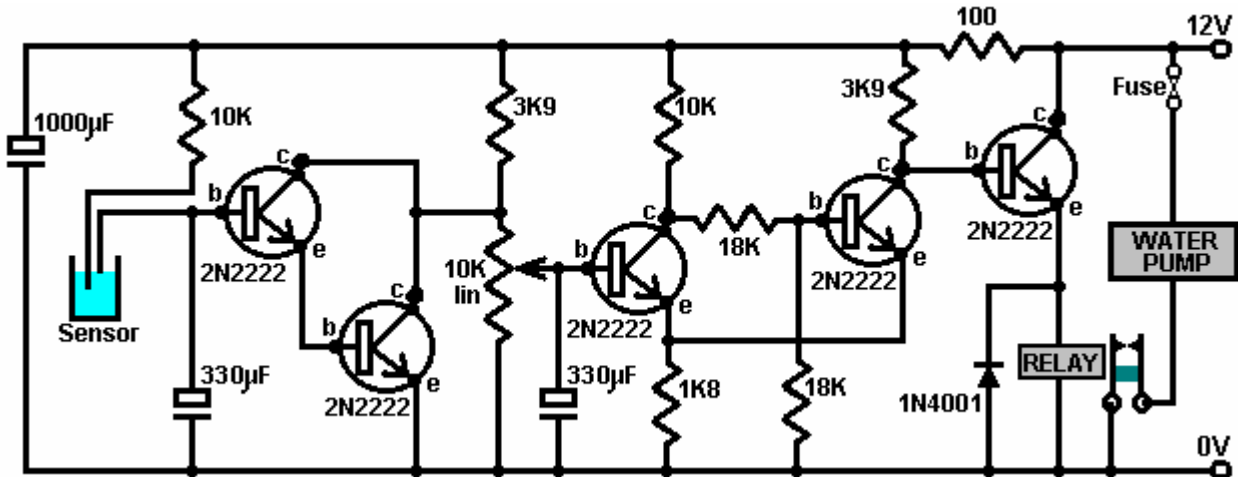

If it is intended to burn the hydroxy gas for heating or cooking applications, then there is a problem. Hydrogen gas burns at such a high temperature that it will melt or cut through most metals. Stan Meyer found this to be a problem and he patented a simple solution (US 4,421,474, included in this set of documents) for lowering the temperature of the flame by mixing in both air and burnt gases:

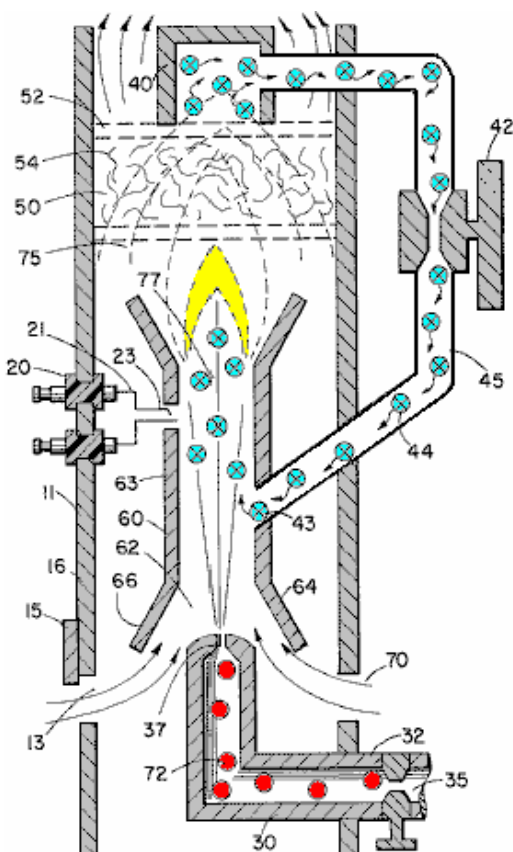

Here, the incoming gas **72** is fed into the burner via a valve **35**. The burning gas rises through a vertical tube **63** and as it does, it draws in outside air through vents **70** and **13** (which has a sliding cover to control the amount of air entering). A pipe cap **40** collects some of the burnt gasses and feeds them back through pipe **45** to mix in with the gasses in the burner column. The amount of gasses passed back is controlled by valve **42**, and the larger the amount of gas being passed back, the lower the temperature generated by the burner. An electric ignition **20** is provided to allow easy ignition of the burner when it is being powered up. The full patent is included in this set of documents and can be found at the www.geocities.com/pjk_over_unity web site or via the www.geocities.com/engpjk site.